



Operation and Service Instructions

Bredal A/S

Type F2

English

No. 02008006

1 Spreader Info

EU Declaration of Compliance

(Directive 89/392/EEA, Annex II, suppl. A)

Manufacturer: BREDAL A/S Overgårdsvej 19, DK 7120 Vejle Ø

Hereby states that

BREDAL Type _____ Serial number _____

Only for Teejet500 control

Cal. figure _____
App. Rate cm ³ /pulse _____
Pulses/100 metres _____
Computer no. _____

Is manufactured in compliance with the machinery directive
(Directive 89/392/EEA) with the latest amendment, and with national provisions

Bredal DK-7120 Vejle Ø

10th Januar 2010



Anders Buhl

Contents

1	Spreader Info.....	2
2	Introduction.....	5
3	Road safety.....	6
4	Technical data.	6
5	Safety.....	6
6	Mounting on tractor.	7
6.1	Adjusting the land wheel.	8
6.2	Adjusting the PTO shaft.	8
7	<i>Setting of application rate.....</i>	9
7.1	Principle of the application system.....	9
7.2	Introduction to the Bulk density kit.	10
7.3	Dose charts.	11
7.4	Introduction to the slide ruler.....	14
7.5	Max. Capacity per minute	15
8	Adjustments for spreading.....	16
8.1	12 – 36 meter working width	16
8.2	Headland spreading on 12-28 meter.....	17
8.3	Headland spreading on 28-36 meter.....	19
9	Trouble shooting	20
9.1	Incorrect balanced spreading.....	21
9.2	Incorrect application rate.....	21
10	Maintenance.	23
10.1	Replacing the V belts.	24
11	Fertiliser quality.....	25
12	Performing a spread test and adjustment of spreading.	26
12.1	Correction of the spread pattern	27
12.2	Performing a spread test with headland spreading.....	29
13	Spreading on narrow Widths.....	30
13.1	Spreading in hilly terrain.....	30
14	Driving to and from tramlines	31
14.1	Start and stop by 15°	32
14.2	Start and stop by 30°	32
14.3	Start and stop by 60°	33
15	Performing a static calibration test.....	33
16	Special fertilisers	34

16.1	N34 Prilled Ammonium Nitrate	34
16.2	Pure potash	34
16.3	Sulphate of Ammonia	35
16.4	Prilled Urea.....	35
16.5	Granulated Urea.....	36
17	Spreading of Slug Pellets, Rape and Mustard.....	37
18	Spreading of slug pellets (only for F2 and F2W with hydraulic rating).....	38
19	Late application.....	39
20	F2W with hydr rating and load cell	40
20.1	Symbol selection	42
21	Start up	43
21.1	Speed sensor	43
21.2	Power supply for the computer	43
21.3	Monting the computer.....	43
21.4	Encoding forward speed	43
21.5	Calibration of hydraulic system	43
22	Operation	45
22.1	Operation screen.....	45
22.2	Operation function 2.....	46
22.3	Hydraulic change of headland gear (Optional equipment).....	47
22.4	Calibration of the application rate.....	48
22.5	Calibration without load cells.....	49
22.6	Main menu.....	50
23	Operation alarms	61
24	System plans	62

2 Introduction

BREDAL type F2 & F2W spreaders are solely constructed for spreading dry granular materials with little or no dust content onto agricultural fields.

It is the responsibility of the operator that the machine he is operating only spreads materials which do not harm his own or others health and property.

The machines must only be operated and maintained by persons who are informed about and fully understand the dangerous parts of the machine.

On the Serial Number plate is indicated machine type (F2 or F2W), the serial number and the production year. In addition is shown the maximum gross and the net weight. The difference is the allowed payload.

This instruction handbook contains settings for your guidance concerning the spreading of most common types of prilled or granular fertilisers found on the market. However, fertiliser quality is not a constant. It may vary from year to year and even from one batch to the next. Due to this BREDAL A/S cannot not take any responsibility for the quality of spreading. This applies to the type fertiliser and to the correct fitting of spare parts onto the machine.

It is solely the responsibility of the operator, to ensure that the machine performs in a way, that achieves acceptable results. BREDAL A/S is constantly testing the fertiliser types, which are found on the market. If any doubt about the spread ability of a particular fertiliser should occur, a simple way of carrying out a field test is described in part 12 in this handbook. You are also always welcome to call the importer of the BREDAL products in your country or to contact the BREDAL factory direct.

Points to consider.

Your fertiliser spreader will each year broadcast several times its own value in fertiliser. The effect of a poor application, due to the lack of maintenance and control, poor fertiliser quality or operation errors, can create yield losses which may many times exceed your investment in the machine. Please give this some thought next time you are buying fertiliser, carrying out a spread test or completing maintenance work.

The machine is manufactured by:

Bredal A/S
Overgårdsvej 19
DK-7120 Vejle Ø
Tlf.: 75 89 51 77
Fax.: 75 89 59 72
Internet: www.bredal.com
E-mail: Info@bredal.com

3 Road safety

It is important that road safety is considered. Check the following points:

- The traffic lights are undamaged, fully operational and are connected to the the plug of the tractor when ever driving on public roads. Remember to clean the lights every time you have been spreading fertiliser.
- Bolts on the lower link arms, drawbar and wheels should regularly be checked and re-tightened. This must be done before you put the machine into operation for the first time.
- When connecting the machine onto the tractor, check that the pins are the correct size or category and that they are proper locked.

4 Technical data.

Type	Capacity (liter)	Net weight (kg)	Loading height (cm)	Width x length (cm)	Working width
F 2 standard	1500	700	136	240 x 130	12 – 36 m
F 2 2500	2400	740	165	240 x 130	12 – 36 m
F 2 3000	3000	750	175	240 x 130	12 – 36 m
F 2 3200	3200	790	165	300 x 130	12 – 36 m.

5 Safety

Never stand close to the discs when they are rotating.

For example, the tractor pto must be disengaged if persons or animals are within a radius of 30 metres from the spread discs of the machine, when operating with 1000 rpm on the tractor Pto and a radius of 20 metres operating with 540 rpm on the pto.

Guards on the pto shafts must be undamaged and correctly mounted.

Never stand on the guard over the discs or on the protection guard, while the discs are running.

Standing on the machine during work and road transport is strictly forbidden.

Avoid loading of hard heavy items, such as metal parts or stones in the hopper. They can cause damage to the machine and be dangerous for anything nearby.

- During service work on type F2 and F2W, the tractor lower link arms must be lowered to lowest position and the machine must be supported by the parking legs.
- During work with type F2 and F2W, the top link must in the correct work position for the machine, that is in-between parallel to the lower link arms and horizontal. If the angle of the top linkage is too steep, it greatly increases the risk of damaging the chassis frame of the machine.
- Connecting type F2 and F2W onto the tractor: Never work in-between tractor and spreader, when anyone is in the cab of the tractor. Make sure that the tractor handbrake is securely tightened and that it is fully functional.

6 Mounting on tractor.

The distance from the ground to the discs must not be less than 75 cm. Optimum is approx. 85 cm, but there is no upper limit for this distance

Check chains must be tightened completely when the spreader is in working position. If this is not adjusted, the pressure between the landwheel and the tractor wheel will cause the spreader to move sideways, which may affect accuracy in spreading.

The landwheel must always run on the centre of the tractor wheel touching both rows of lugs on the tractor tyre.

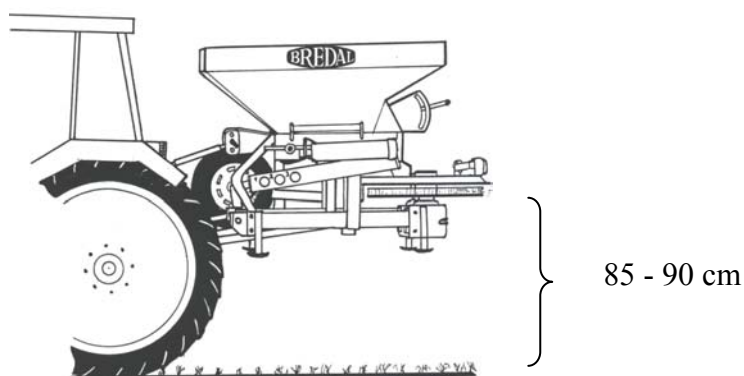

- Type F2 : The three point linkage points meets the measurements for the ISO standard for Cat.2 tractors.
- Type F2W : The three point linkage points meets the measurements for the ISO standard for Cat. 3 tractors.

Make sure that the lower link arms and the top linkage are as close to parallel with each other as possible. A steep angled top linkage may overload the tractor and machine attachment points.

The spreader must be mounted **parallel** to the surface or **incline slightly towards the tractor**.

The spreader must not incline backwards, not even when fully loaded. It must be positioned straight behind the tractor, i.e. perpendicular to the driving direction with equal parts of the machine to the left and right side of the centreline of the tractor.

6.1 Adjusting the land wheel.

Drive to the the feed mechanism is engaged/disengaged hydraulically by connecting the hose from the land wheel to a single acting spool valve. Always remember to close the Ball Valve on the hose, to lock the landwheel when driving on the road. The spool valves on modern tractors rarely have no leakage and may not withstand the pressure of the spring system on the landwheel over a distance. Forgetting to close the ball valve, may risk metering fertiliser onto the road, losing expensive materials and having a negative impact on the environment. On some of the F2 and F2W versions der might be a pilotcontrolled valve instead of the ball valve, this valve automatically closes every time it's operated.

The landwheel drive feed mechanism driving the feeding belts, has the advantage that the forward speed can be freely selected , without affecting the application rate. Due to the fact that the landwheel is driving on the surface of the tractor or spreader rear wheel, one metre driven forward in the field will be transferred to the surface of the landwheel, which then also will turn one metre. Therefore you are free to change the size of the tractor or spreader wheel, without affecting the accuracy of the metering system e.g. changing from flotation to row crop wheels.

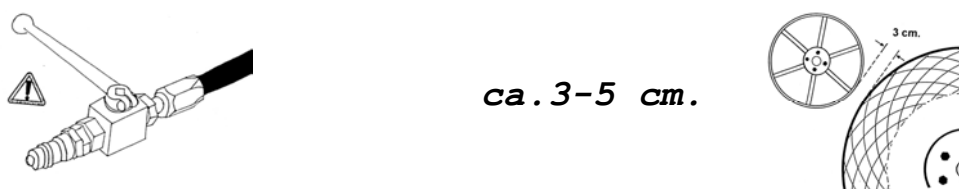

6.2 Adjusting the PTO shaft.

Check the length of the Pto shaft and shorten if necessary to ensure it cannot be “bottomed” under any circumstances – particularly when the spreader is in the raised position. The minimum overlap is 20 cm.

Remember: *If the pto shaft is shortened the ends must be filed to debur to avoid the two halves sticking together or wearing prematurely. Regularly grease the inner tube and universal joints*

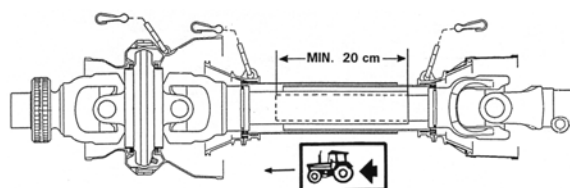

7 Setting of application rate

To achieve the correct application rate the following measurements should be checked:

1. At Scale 8 on the rear door handle, there should be a distance of 40 mm measured vertically between the floorbelt and the bottom edge of each regulating slide shown as B below. Always move the scale adjustment handle down to the setting required. Adjust using the lock nuts on the threaded rod above each regulating slide.

The distance between the side rubbers should be between 112mm and 115mm directly below the rear doors shown as C below

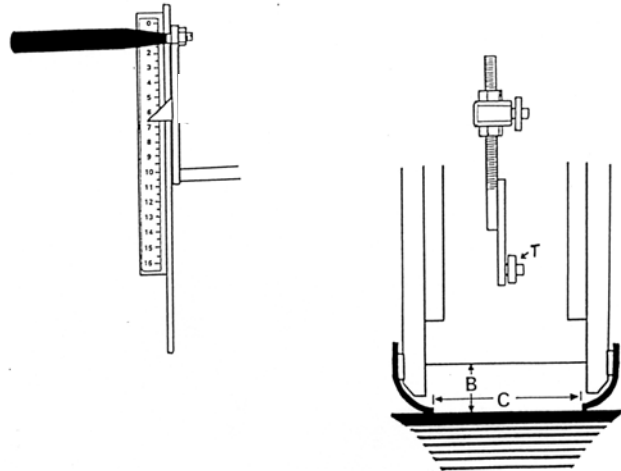

7.1 Principle of the application system.

The Bredal F2 / F2W machines are built with an active metering system consisting of two floorbelts with adjustable reardoor providing two precise openings where the material metered out of the hopper.

Fertiliser is positively fed from the hopper and for a particular setting of the regulating slides the same volume is metered from the hopper whether the material is prilled, granular, blended or straights. A simple calculation from the application rate in kg/ha and the bulk density of the fertiliser means that by referring to a single chart for the spread width required is the only information needed to set the spreader.

The flow is controlled by the landwheel. The faster you travel, the faster the floorbelts turn which provides the correct amount spread per hectare, no matter what forward chosen.

7.2 Introduction to the Bulk density kit.

To set the application rate it is necessary to know the Bulk Density of the material to be spread. A Bulk Density kit can be supplied with the spreader to give a direct reading.

Fill up the plastic container with the material to be loaded into the spreader. Gently tap the container on the floor and refill so that the material is level with the container top edge. Hang the container in the “W” cut into the shorter end of the arm (use the x1 cutout). Adjust the counterbalance until the balance arm is horizontal. Note the Bulk Density by reading directly off the scale on the balance arm, taking a reading in line with the head of the fine adjustment bolt.

To “Zero” the Bulk Density Kit, fill the container with water and hang on the x1 cutout on the balance arm. Slide the balance weight until the arm is balanced in the horizontal position. The head of the adjuster bolt on the counterweight should read 1.0 kg/l. To correct, release the locknut on the adjustment bolt, reset the position and retighten.

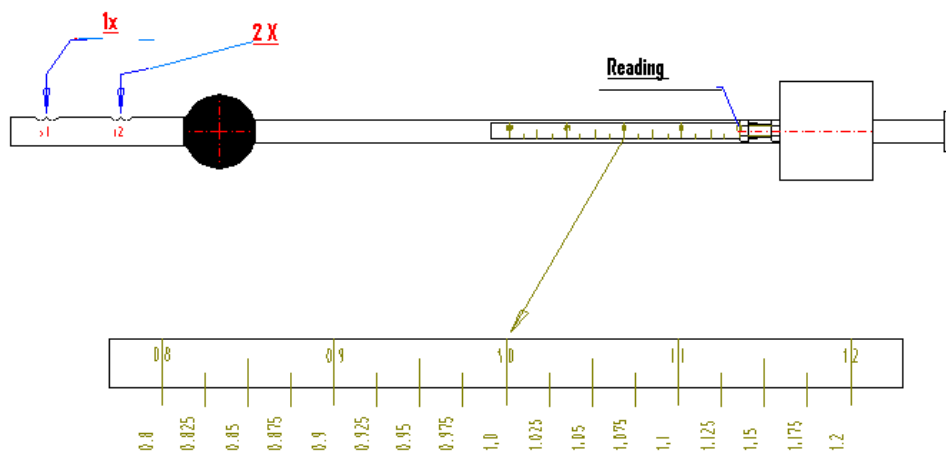

Fig. 4. Bulk density kit for determination of specific bulk density.

7.3 Dose charts.

12 m				
Scale	Axle ½	Axle 1	Axle 2	Axle 3
-2	48	93	174	301
-1	57	111	209	367
0	66	129	244	433
1	75	147	279	499
2	84	165	314	565
3	94	183	349	631
4	103	201	384	698
5	112	219	419	764
6	121	237	454	830
7	130	254	489	896
8	139	272	523	962
9	148	290	558	1028
10	157	308	593	1094
11	166	326	628	1160
12	175	344	663	1227
13	184	362	698	1293
14	193	380	733	1359
15	202	398	768	1425
16	211	416	803	1491

15 m				
Scale	Axle ½	Axle 1	Axle 2	Axle 3
-2	38	74	139	241
-1	46	89	167	294
0	53	103	195	346
1	60	118	223	399
2	67	132	251	452
3	75	146	279	505
4	82	161	307	558
5	90	175	335	611
6	97	190	363	664
7	104	203	391	717
8	111	218	418	770
9	118	232	446	822
10	126	246	474	875
11	133	261	502	928
12	140	275	530	982
13	147	290	558	1034
14	154	304	586	1087
15	162	318	618	1140
16	169	333	642	1193

Axle ½ is optional equipment.

16 m				
Scale	Axle ½	Axle 1	Axle 2	Axle 3
-2	36	70	131	226
-1	43	83	157	275
0	50	97	183	325
1	56	110	209	374
2	63	124	236	424
3	71	137	262	473
4	77	151	288	524
5	84	164	314	573
6	91	178	341	623
7	98	191	367	672
8	104	204	392	722
9	111	218	419	771
10	118	231	445	821
11	125	245	471	870
12	131	258	497	920
13	138	272	524	970
14	145	285	550	1019
15	152	299	576	1069
16	158	312	602	1118

18 m				
Scale	Axle ½	Axle 1	Axle 2	Axle 3
-2	32	62	116	201
-1	38	74	139	245
0	44	86	163	289
1	50	98	186	333
2	56	110	209	376
3	63	123	233	421
4	69	134	256	465
5	75	146	279	509
6	81	158	303	553
7	87	169	326	597
8	93	181	349	641
9	99	193	372	685
10	105	205	395	729
11	112	217	419	773
12	117	229	442	818
13	123	241	465	862
14	129	253	489	839
15	135	265	512	950
16	141	277	535	994

20 m				
Scale	Axle ½	Axle 1	Axle 2	Axle 3
-2	29	56	104	181
-1	34	67	125	220
0	40	77	146	260
1	45	88	167	299
2	50	99	188	339
3	56	110	209	379
4	62	121	230	419
5	67	131	251	458
6	73	142	272	498
7	78	152	293	538
8	84	163	314	577
9	89	174	335	617
10	94	185	356	656
11	100	196	377	696
12	105	206	398	736
13	110	217	419	776
14	116	228	440	815
15	121	239	461	855
16	127	250	482	895

24 m				
Scale	Axle ½	Axle 1	Axle 2	Axle 3
-2	24	47	87	151
-1	29	56	105	184
0	33	65	122	217
1	38	74	140	250
2	42	83	157	283
3	47	92	175	316
4	52	101	192	349
5	56	110	210	382
6	61	119	227	415
7	65	127	245	448
8	70	136	262	481
9	74	145	279	514
10	79	154	297	547
11	83	163	314	580
12	88	172	322	614
13	92	181	349	647
14	97	190	366	680
15	101	100	384	713
16	106	208	402	746

Axle ½ is optional equipment

28 m				
Scale	Axle ½	Axle 1	Axle 2	Axle 3
-2	21	40	75	129
-1	24	48	90	157
0	28	55	105	186
1	32	63	120	214
2	36	71	135	242
3	40	78	150	270
4	44	86	165	465
5	48	94	180	327
6	52	102	195	356
7	56	109	210	384
8	60	117	224	412
9	63	124	239	441
10	67	132	254	469
11	71	140	269	497
12	75	147	284	526
13	79	155	299	554
14	83	163	214	815
15	87	170	329	611
16	90	178	344	639

30 m				
Scale	Axle ½	Axle 1	Axle 2	Axle 3
-2	19	37	70	120
-1	23	44	84	147
0	26	52	98	173
1	30	59	112	200
2	34	66	126	226
3	38	73	140	252
4	41	80	154	279
5	45	88	168	306
6	48	95	182	332
7	52	102	196	358
8	56	109	209	385
9	59	116	223	411
10	63	123	237	438
11	66	130	251	464
12	70	138	265	491
13	74	145	279	517
14	77	152	293	544
15	81	159	307	570
16	84	166	321	596

32 m				
Scale	Axle ½	Axle 1	Axle 2	Axle 3
-2	18	35	65	113
-1	23	42	78	138
0	25	48	92	162
1	28	55	105	187
2	32	62	118	212
3	35	69	131	237
4	39	75	144	262
5	42	82	157	287
6	45	89	170	311
7	49	95	183	336
8	52	102	196	361
9	56	103	203	386
10	59	116	222	410
11	62	122	236	435
12	66	129	249	460
13	69	136	262	485
14	72	143	275	510
15	76	149	288	534
16	79	156	301	559

36 m				
Scale	Axle ½	Axle 1	Axle 2	Axle 3
-2	16	31	58	100
-1	19	37	70	122
0	22	43	81	144
1	25	49	93	166
2	28	55	105	188
3	31	61	116	210
4	34	67	128	233
5	37	73	140	255
6	40	79	151	277
7	43	85	163	299
8	46	91	174	320
9	49	97	186	343
10	52	103	198	365
11	55	109	209	387
12	58	115	221	409
13	61	121	233	431
14	64	127	244	453
15	67	133	256	475
16	70	139	268	497

Axle ½ is optional equipment

7.4 Introduction to the slide ruler.

BREDAL has developed a quick and simple to use slide rule for precise setting of the BREDAL F2 spreader, without the need of a calculator.

To use the slide you only need to know the required application rate in **Kg/ha** and the bulk density in **Kg/ltr**.

Find the setting following the instructions found below.

Example: to be spread 400 kg./ha.spec. bulk weight = 0,95

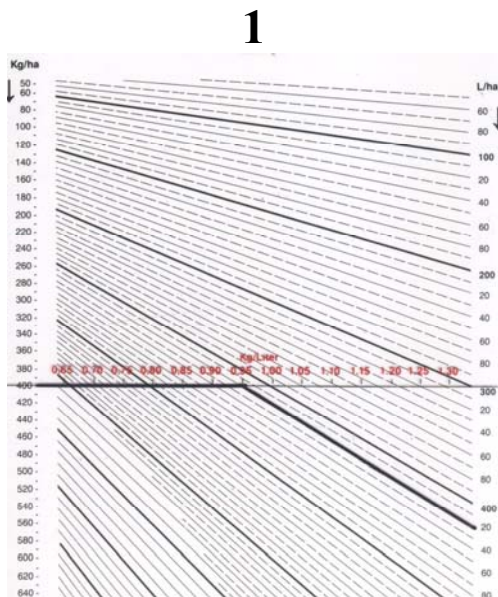

The inner piece of the slide rule is moved to where the Kg/ha figure 400 on the left side is lined up with the red Bulk Density scale line. From the Bulk Density figure (kg/liter), follow the line down to the L/ha scale at the right hand side and note the number. In the example the figure is 420.

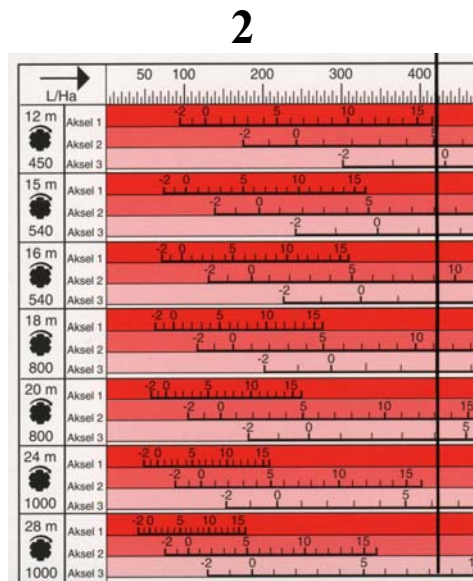

Turn over the slide rule and on the reverse line up the cursor with the number on the top scale from step 1. The settings for the spreader can now be read directly.

Example; if spreading at 24m, line up the 420 figure and read directly the Axle and Scale Handle settings

7.5 Max. Capacity per minute

The V-belt transmission may not be overstressed.

The output rate may not exceed more than:

- 250 kg/minute by 540 rev/min or
- 300 kg/minute by 1000 rev/min.

The way of calculating the output rate is following:

$$\frac{\text{Km/h} \times \text{Working width} \times \text{kg/ha}}{600} = \text{kg/minute}$$

The maximum forward driving speed can be calculated the following way:

$$\frac{180.000}{\text{Working width} \times \text{kg/ha}} = \text{km/t (max)}$$

8 Adjustments for spreading

Damaged or very worn spreading vanes should be changed to new ones !

Spreading vanes with holes will throw the fertiliser in the wrong direction !

It is **SOLELY** the operator's responsibility that spreading discs and vanes are correctly mounted.

Check also the 2 downshutes (slopes for the fertiliser to fall down to the spreading discs), the downshutes must be free residues of fertiliser.

8.1 12 – 36 meter working width



In order to spread between 12 and 36 metres, the spreader is equipped with spreading discs each with 6 spreading vanes.

Listed in the Chart below are the settings of the Downchutes and the Pto Speed for spreading in the field.

Spreading in the Field

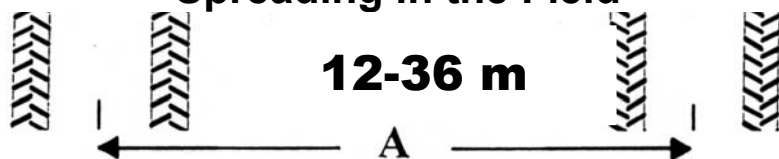
12-36 m

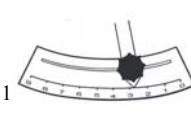

A	2X ¹ 	
12 m	0	450
15 m	1	540
16 m	1	540
18 m	2	600
20 m	2,5	700
24 m	4	900*
28 m	4	1000*
30 m	4,5	1000*
32 m	5	1000*
36 m	5,5	1000*

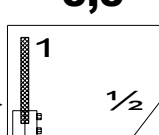

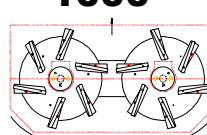
***Prilled fertiliser max 800 rpm.**



Please note that the gear-selector must be placed on 1



2x1 = The setting is for both downchutes

8.2 Headland spreading on 12-28 meter

When engaging the Headland spreading system, the revolutions of the left spreading disc are reduced by approximately 50%

The gear-selector on the spinner box is set on $\frac{1}{2}$, which reduces the revolutions of the left spreading disc (towards the headland) - the right spreading disc, into the field, continues with full revolutions.

The Downchutes and Pto speed are adjusted according to the below chart, and it is necessary to drive with the left spreading disc towards the headland i.e drive clockwise around the field boundary.

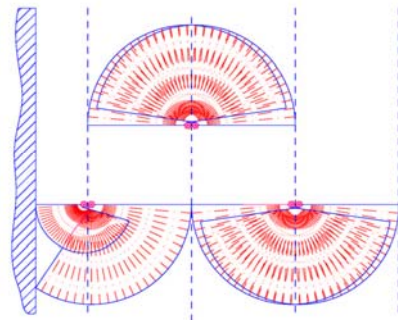

The chart below has the settings for 12-28 m headland spreading

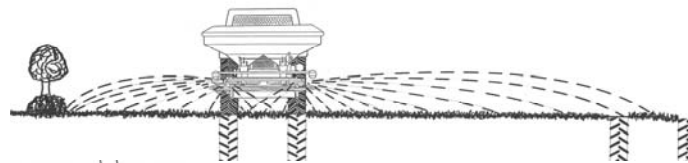

Headland spreading on 12-28 m

Listed in the chart below the settings of the downshute and Pto speed for headland spreading on 12-28 m.

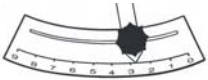
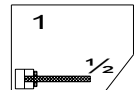

A			
12 m	4,0	$\frac{1}{2}$	400
15 m	4,0	$\frac{1}{2}$	450
16 m	4,0	$\frac{1}{2}$	500
18 m	5,0	$\frac{1}{2}$	650
20 m	5,0	$\frac{1}{2}$	750
24 m	5,5	$\frac{1}{2}$	950
28 m	6,0	$\frac{1}{2}$	1000



Note that the gear selector **MUST** be set for Headland spreading

If you require the full rate toward the headland to optimise yield, increase on the chart with the Pto speed, the figure by up to 100 revolutions/minute where possible.
If you require no spreading beyond the headland for environmental considerations, reduce the chart Pto speed figure by up to 100 revolutions per minute.

8.3 Headland spreading on 28-36 meter

When engaging the Headland spreading system, the revolutions of the left spreading disc are reduced by approximately 33%

The gear-selector on the spinner box is set on **headland**, which reduces the revolutions of the left spreading disc (towards the headland)

The downcutte and Pto speed are adjusted according to the below chart, and it is necessary to drive with the left spreading disc towards the headland.

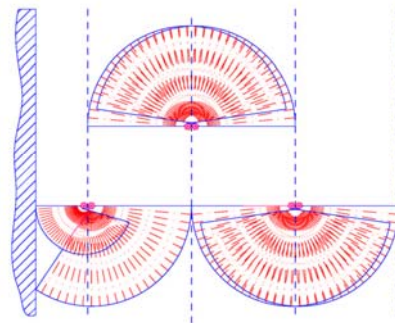

If the machine is mounted with downcuttes that has a small hatch, the hatch on the downcutte towards the headland (Left side) must be opened while spreading headland spreading.

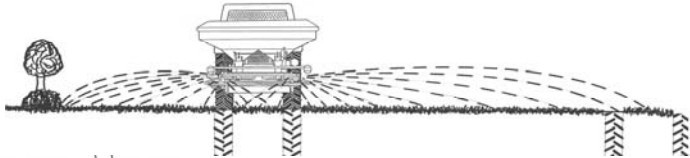

Headland spreading 28-36 m

Listed in the chart below the settings downcutte and Pto speed for headland spreading on 28-36 m.

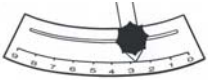
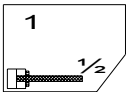

A			
28 m	6,0	1/2	650
30 m	6,0	1/2	700
32 m	6,0	1/2	800
36 m	6,5	1/2	900

 **Note that the gear selector MUST be set at Headland spreading**

If you require the full rate toward the headland to optimise yield, increase the chart Pto speed figure by up to 100 revolutions/minute where possible.

If you require no spreading beyond the headland for environmental considerations, reduce the chart Pto speed figure by 100 revolutions per minute, and reduce the application rate by 10%.

9 Trouble shooting

WARNING !!!

- The spreading vanes must always be mounted correctly on the discs.
- Incorrectly mounted vanes may cause large changes in the spread pattern.

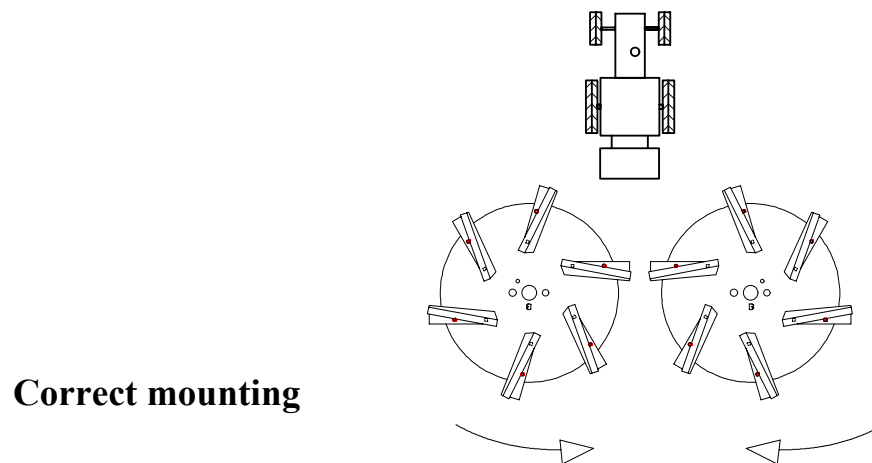

Responsibility!!!

- Damaged or very worn spreading vanes should be changed to new ones !
- Spreading vanes with holes will throw the fertiliser in the wrong direction !
- It is **SOLELY** the operator's responsibility that spreading discs and vanes are correctly mounted !

**Guidance in adjusting the evenness of the spreading you will find under:
Spread Test and adjustment of spreading**

9.1 *Incorrect balanced spreading.*

If the spread pattern is not balanced to the left and right, or when there is too much fertiliser at the overlap on one side, first check that the spreading vanes are in good order (not worn or bent) and that they are correctly mounted, see fig. above. Also check that top link of the machine in the working position is in-between parallel with the lower link arms and the horizontal. If the angle of the top link is too steep, it greatly increases the risk of damaging the chassis frame of the machine.

Check that the downchutes are clean with no material build up.

Then check that the left and right feed gates have the same opening and distances as specified in section 8.2. Check that the downchutes are set at the same position for metering material to the same point on each spreading disc. To check this precisely, Bredal A/S offer a tool (a downchute measuring instrument) with instruction, that can be ordered.

If the spread pattern continues to be non-symmetrical, the 4 bolts on which the spreading disc transmission is mounted can be loosened and the whole transmission can be adjusted a little toward the side which spreads too little fertilizer. (Approx. 0,5 – 1.0 mm for every % difference from the 50% that should be spread to each side).

9.2 *Incorrect application rate*

If the spreader does not meter the correct application rate, follow the procedure below :

1. Check whether the Bulk Density of the fertilizer is correct. For this use the Bulk Density Kit to directly read the value (see section 6.2 to zero the kit).
2. Check whether the conversion from kg/ha to litre/ha is calculated correctly (section 6.3).
3. Check whether the landwheel turns evenly. If the landwheel bounces on the tractor wheel, the spreader will not meter correctly. This can be checked by driving a distance on a road without having fertilizer in the hopper – or by dismounting the PTO shaft between the landwheel and the 3-axled gearbox. The landwheel must run 55,5 revolutions per 100 metre forward travel of the tractor. A Mechanical counter is of assistance for this purpose (see extra equipment)
4. Check the setting of the rear doors and whether the side rubbers are correctly adjusted (see fig. 19): ***B = 40 mm at scale setting 8 and C = 112 -> 115 mm between the side rubbers at the slide opening.*** When checking measurement B, we recommend that you use a piece of steel or wood with the dimensions of 40 mm height and 112-115 mm width (C). You must be able to slide this under the rear door, without moving the side rubbers or rear gate.

B = 40 mm

C = 110-115 mm

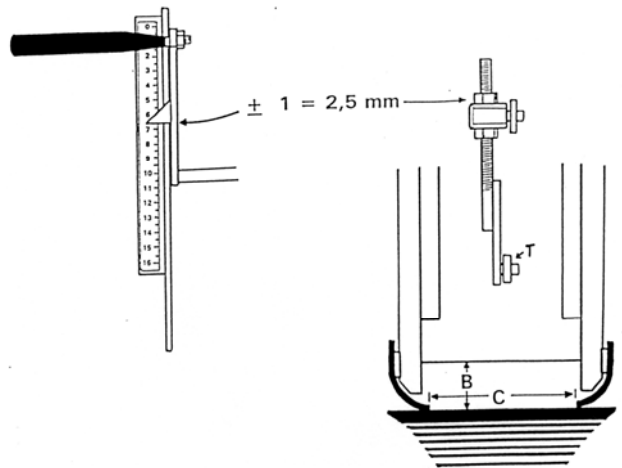

Fig. 19. Regulating rear door opening

The rear doors, connecting rods and the adjusting axle must run freely, otherwise the correspondence between scale settings and downshute opening will be incorrect. Particularly check that the pivot point " T " moves freely and is lubricated. Always move the handle down to the scale number when adjusting the rear doors.

If the spreader continues to meter incorrectly after the above checks have been carried out, then it is possible to adjust the mechanism to match the scale reading with the amount actually metered in practise. The adjustment rods on each regulating slide can then be used to correct the error. One digit on the scale corresponds to 2,5 mm movement of the rear door, which means that everytime the nut on the adjusting rod is moved 1,5 turns, the rear door is lowered/raised by 1 step on the scale (Fig 19).

Alternatively a static calibration test of application rate can be completed. For further instruction see section 15

10 Maintenance.

The spreading system should be clean and intact. Worn out spreading discs or vanes may cause uneven spreading.

The side rubbers of the conveyor should be firmly pressed onto the conveyorbelt.

The conveyor belts should be tensioned and run correctly. If one of the floorbelts is running so much out of line that the edge is catching on the frame, adjust by tightening or loosening the adjuster with a single nut. Turn the nut a maximum half turn and run the floorbelt to allow it to settle in the new position. Only adjust the belt tensioner with the two locknuts if the overall belt tension needs to be increased to prevent belt drive slip.

V-belts in transmission should be checked and tightened. It should not be possible to turn the discs in the same direction. Check by pushing against a vane on the left disc, while pulling a vane on the right disc. Loosen the belt tensioner lock nut, then tighten the belt tensioner until the discs just slip. Then tighten the adjuster one more full turn and retighten the locknut. Check after the first load then daily. ALWAYS CHECK TENSION WHEN THE BELTS ARE COLD!

Washing – after each usage the spreader should be washed and greased. Wash down from the hopper to the disc cover and to the discs/spinner box. After cleaning run the spreader for 2 – 3 minutes to allow air movement to dry the surfaces.

Storage: Before putting the machine away after the season it must be thoroughly cleaned to remove any fertiliser residue, all greasing points lubricated and the machine sprayed with a thin layer of oil. Use either a propriety protection oil or hydraulic oil, which are designed to be in contact with rubber components and are thin to give very good cover. However, remember to wipe off any excess oil from the floorbelts after application as oil on rubber may cause damage in the longer term. You can also cover the floorbelts with an absorbent material when spraying. The material should be removed after application and again the floorbelts wiped to remove any excess oil.

The floorbelt drive wheel must be in the forward position with the least spring pressure when stored. The hydraulic cylinder is then fully closed to protect the piston rod and seals against damage.

PTO shafts for both the spinner box and floor belt drives should be dismantled and the cross joints and telescopic tubes regularly greased

10.1 Replacing the V belts.



1) Spreadbox without V belts



2) V-belt around pulley 1 and 2



3) twist 180° and around pulley on headland gear



4) around tightening pulley and V-belt must be tightened.



5) Tightening on headland gear to be mounted with V-belts.



6) Bolt for thightener to be mounted with feder and thightened. To be tightened until feder has 45 mm left.



7) Changing fork and plast bearing 1 to be mounted



8) Handle and plastbearing 2 and 3 to be mounted



9) Feder guidance and feder to be mounted



10) Handle to be moved in middle position and mount lock pin..

11 Fertiliser quality

The F2 and F2W have a variable spread width from 12 to 36 metres. At 540 Pto rpm, the fertiliser particles leave the vanes at approx. 130 kph (80mph) and at 1000 Pto rpm the speed is approx. 240kph (150mph). The fertiliser is therefore exposed to large centrifugal loadings to achieve these speeds. This means that particularly for the wider widths the fertiliser must be of high quality. The most important properties are:

Particle strength: is measured by placing a fertilizer grain on an accurate digital scales and pressing down on the granule with, for example, with the flat end of a pencil. The weight which is shown when the particle shatters, is an indicator for the particle strength of the fertilizer. Be sure to try several granules (both big and small) and then calculate the average particle strength (fig.26). Particle strength decreases with humidity and will remain decreased even if the material is dried again. Always keep fertiliser covered/sealed with plastic.

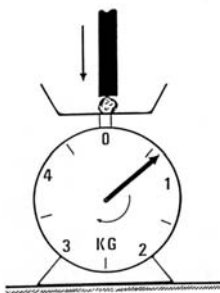

Fig. 26. Scale for measuring the particle strength

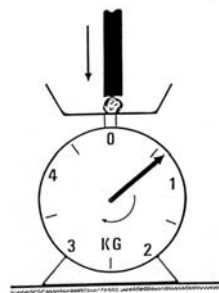

Fig. 26. Scale for measuring the particle strength

Particle Size: can be measured using the BREDAL Sieve Box. Fill up the space above the screen with the largest mesh. Put on the lid and shake until no more changes of distribution occur. Turn the box with the lid upwards. Measure the number of mm in each compartment. Find out the % distribution for each compartment (fig.27) and determine the Mean (average) Particle size. The smaller the mean size, the less wide the spread width.

Bulk Density can be calculated from the weight in a litre measure or a 10-litre bucket. The greater the amount, the more precise the measure. BREDAL offers a Bulk Density kit mounted on the spreader which directly indicates the bulk density. (Instructions under section 6)

Particle Shape can be judged visually. The smoother and rounder the granule, the better it flies in the air and the better it flows on the vanes. A very sharp edged particle (like broken stones) or a particle with a very uneven surface has poor aerodynamic properties and may have difficulty reaching to larger working widths.

High Dust Content is obvious if a large amount of material is gathered below the smallest sieve, but the dust content can often be judged visually. High dust content may limit the overall spread width and may cause build-up on vital parts in humid conditions

Standard settings of this machine a based on the following minimum requirements:

Working width	Working width	Working width	Working width
12-16 m	12-16 m	12-16 m	12-16 m
18-20 m	18-20 m	18-20 m	18-20 m
24-28 m	24-28 m	24-28 m	24-28 m
30-36 m	30-36 m	30-36 m	30-36 m

12 Performing a spread test and adjustment of spreading.

If there is concern that the machine is not spreading correctly or the fertilizer type being has other properties outside the parameters in Section 11, a Spreading Test is recommended.

During the execution of the test it is important to consider the following points:

1. The test must take place under dry conditions (field/machine)
2. The test must take place in a field with a good crop, about 10 cm of strong cover, so that bouncing particles or ricochets are avoided
3. Carry out the test on a flat part of the field and to place the trays carefully to be as horizontal as possible. The test **must** be completed using the same forward speed, which normally is used for spreading (optimum is 10 – 15km/h if the field conditions allow).
4. Worn out spreading vanes should be replaced.
5. Make sure to run about 100 to 200 kg fertilizer through the spreader before the test is carried out. There will always be a coating left from old fertilizer, other residue or rust on the discs and vanes of the spreader, which need to be worn off before the test to show a true picture of the spreading performance.
6. The simplest way carry out the test is to place two calibration trays at $\frac{1}{2}$ the working width to both left and right sides of the centre of 3 bouts. Position the remaining trays as shown in fig. 29. Travel up the first bout, then down bout 2 and back up bout 3 to give a three full overlapping passes. In order to get the enough material into the trays needed for an estimation, it is necessary to spread about 400 kg/ha or pass the trays several times (fig 29).
7. Make sure to keep spreading well past the spread trays, as the fertilizer is thrown as far to the rear of the spreader as it is to the side.

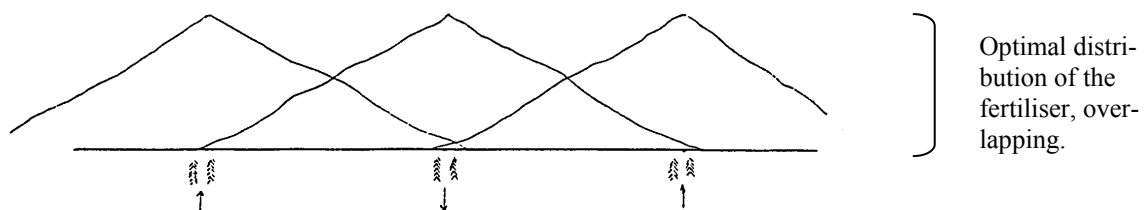

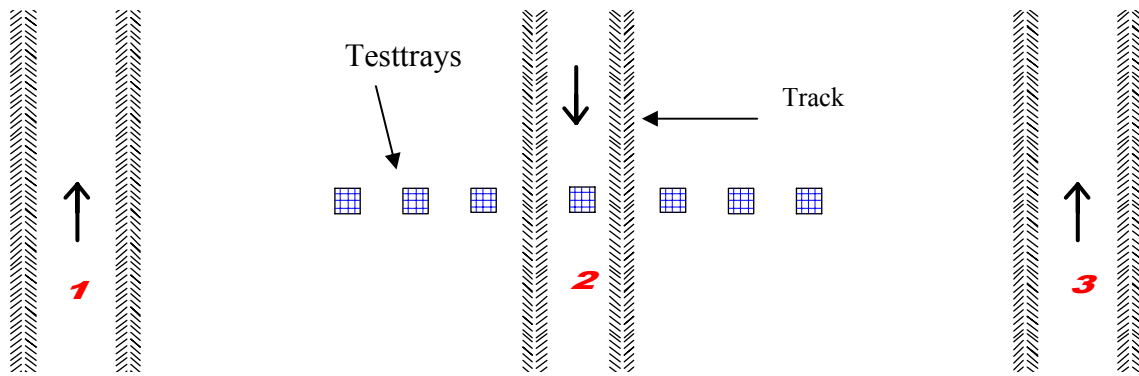

Positions of the testing trays BREDAL recommends using 7 trays for testing.

12.1 Correction of the spread pattern

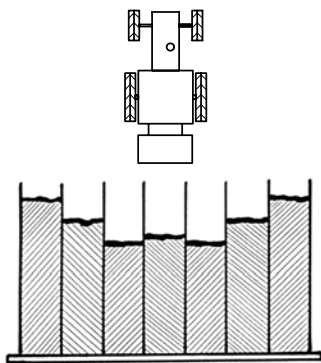

Fig. 30. Measuring Tubes:

Too much fertilizer between the tracks.

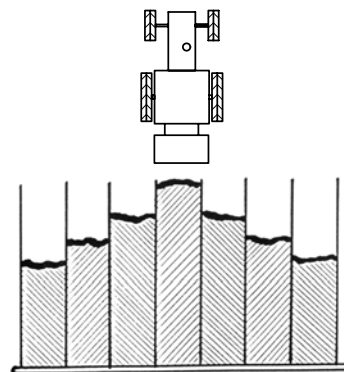

Fig. 31. Measuring Tubes:

Too much fertilizer behind the spreader.

Too much fertilizer between the tracks? (fig. 30)

- A. **12-16 m:** Increase the Pto speed from 450 to 540 rpm at 12 m spread width and increase from Pto speed 540rpm by 100 rpm per test at 15-16 metre until the spreading is corrected.
- B. **18-28 m:** The downshute scale (fig. 32) should be moved towards 0. If the initial test with standard settings is unacceptable, move the downshutes 1-2 full scale marks. If the second test shows that this was too much, the difference between the two tests will indicate how far the scale has to moved back.
- C. **30-36 m:** The downshute scale (fig. 32) should be moved towards 0. If the initial test with standard settings is unacceptable, move the downshutes 0,5-1 scale marks.

Too much fertilizer behind the spreader? (fig. 31)

- A. **12-16 m:** Adjust the downshutes by increasing 2 scale marks per test until the test is correct.
- B. **18-28 m:** Providing the fertilizer observes the requirements on particle strength and size (section 11.2), increase the downshute scale setting by scale 1-2 full scale marks towards 9.
- C. **30-36 m:** Providing the fertilizer observes the requirements on particle strength and size (section 11.2), increase the downshute scale setting by scale 0,5-1 full scale marks towards 9.

If the particle strength and/or the grain size do not observe the requirements (stated under 11.2), the combination of tractor Pto speed and the downshute scale setting can be changed, as shown below:

Lower the tractor Pto speed by 20%. The spreading mechanism will then be more gentle on the fertilizer (lower particle strength requirement) and drop the fertilizer earlier, thus leaving more fertilizer between the tracks.

Should this not be sufficient, move the downshute scale one mark at a time towards 9. Be aware of the fact that this way of spreading is much more sensitive to fluctuations in the fertilizer quality, fluctuations in the distance between each bout and variations in the tractor Pto speed than the normal recommended standard settings. The overlap is significantly reduced because a box shaped spreading curve when compared to the normal double, double overlapping spread pattern.

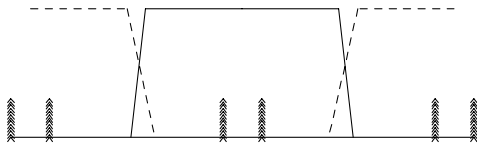

Fig. 33. Spreading with little overlapping

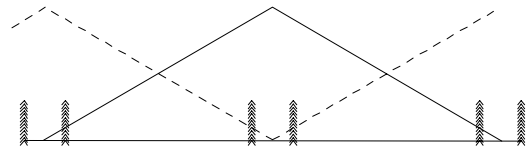

Fig. 34. Spreading with double, double overlapping

12.2 Performing a spread test with headland spreading.

Place the trays as shown in fig. 35. Adjust the machine as mentioned under section 7. If the machine drops too much fertilizer over the boundary line; lower the number of revolutions with 50 rpm per test, until the spreading is acceptable. In the event of the opposite with too little fertilizer at the boundary line, the number of revolutions should be raised with 50 rpm per test

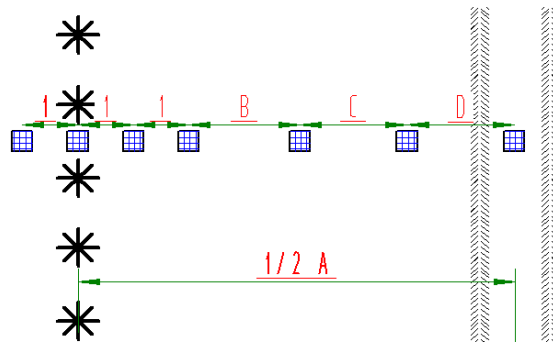

Fig. 35. Setting out of test trays at headland spreading

The shown numbers are in metres. Position the remaining trays with B,C and D equal over the remaining distance.

13 Spreading on narrow Widths

When spreading narrow widths, for example if there is a narrow width remaining after working across the tramlines of a field, the following procedure should be followed:

If the narrow working width is 60% of the normal bout width, the missing working width will consequently be 40%.

Half of this is 20%. Subtract this amount (20%) from the application rate of the two bouts either side of the narrow width remaining, as shown below.

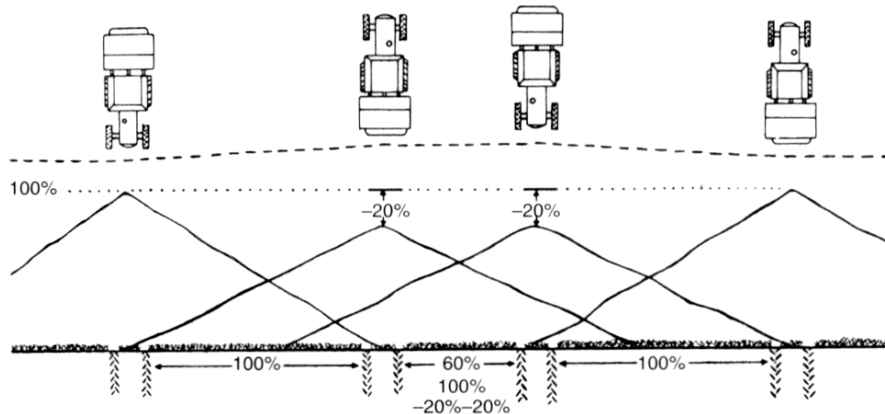

When spreading narrow widths, for example if there is a narrow width remaining after working across the tramlines of a field, the following procedure should be followed:

Example:

If the narrow working width is 60% of the normal bout width, the missing working width will consequently be 40%.

Half of this is 20%. Subtract this amount (20%) from the application rate of the two bouts either side of the narrow width remaining, as shown below.

Tramline smaller than the normal tramline width between 1. and 2. tramline.

Exampel:

If there is a tramline where the working width is only 60% of the normal working width wich leaves 40% of the spread area.

Then the application rate needs to be reduced by 40 on the 2 tramlines on each side of the reduced tramline..

13.1 Spreading in hilly terrain

If the areas are in a very hilly condition, then choose a high floorbelt speed and a low hight of the rear doors.

14 Driving to and from tramlines

Spreading characteristic of Bredal F2 spreaders is to operate on a double, double overlap system of spreading, which produces a full half circle of spread with a very shallow tapering pattern

In normal field work, this results in an accurate and even spread over a wide range of materials. To ensure that this evenness is maintained at headland boundaries, it is important to follow the technique shown in the diagrams below.

The Bredal double, double overlap tapering pattern means that it is not necessary to shut off the feed to the right or left discs when approaching headland borders at an angle. By following the simple procedure in the diagrams, correct and even spreading of the whole field will be achieved with the normal single shut off control without the complexity of individual shut offs.

Each diagram shows the point at which spreading should be shut off when approaching or leaving the headland at 90 degrees or at alternative angles. The shut off point depends on the angle of approach as shown on the diagrams and in each case is when the tractor rear wheels pass that point.

When moving away from the headland, spreading should always be started when the tractor rear wheels pass the spread limit . . . shown as a dotted line (- - -) on each diagram.

Practise of this simple technique will ensure accurate and even application with minimum risk of over and under application and all by the simple operation of the single lever on/off control

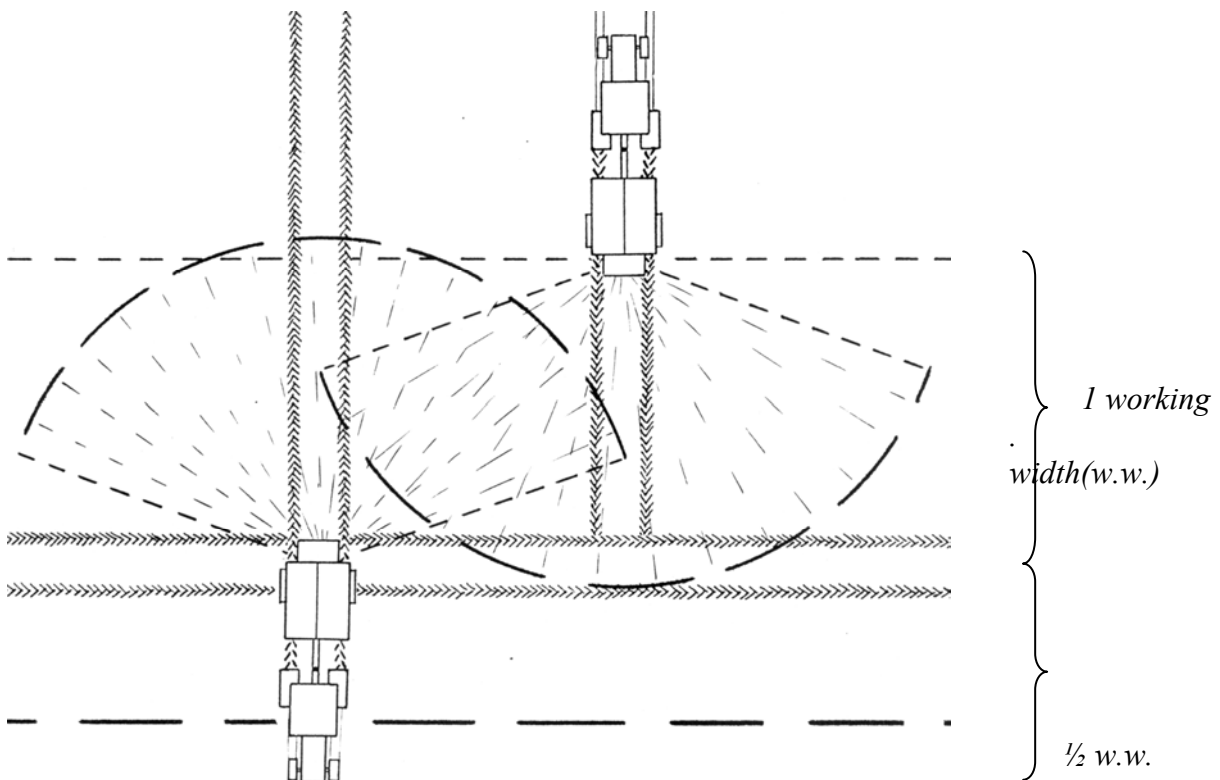

14.1 Start and stop by 15°

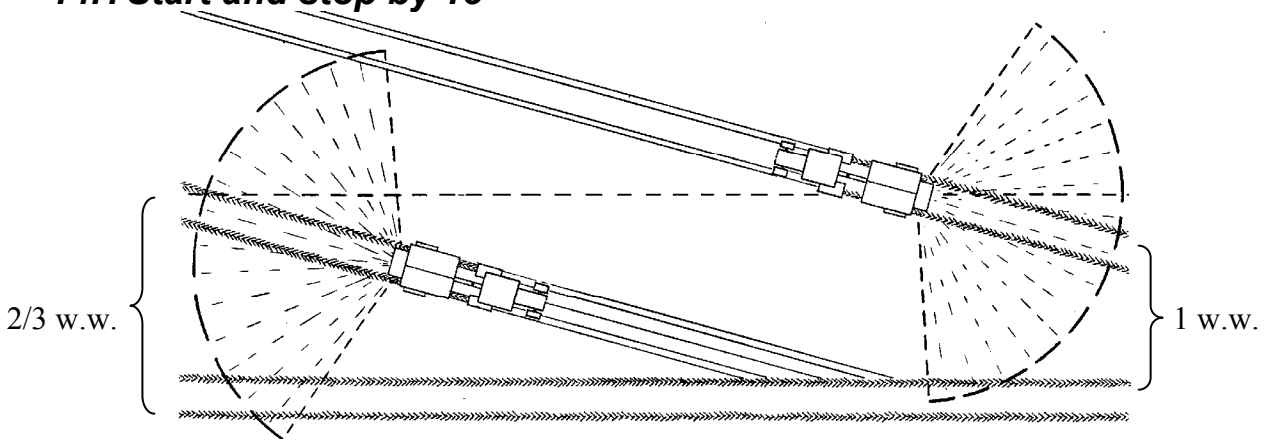

Towards headland tramline:

Disengage the metering system at a distance of $\frac{2}{3}$ the working width from the headland tramline. Slowly reduce the engine rpm before you disengage.

Away from tramline:

Engage the metering system at the working width from the headland tramline.

14.2 Start and stop by 30°

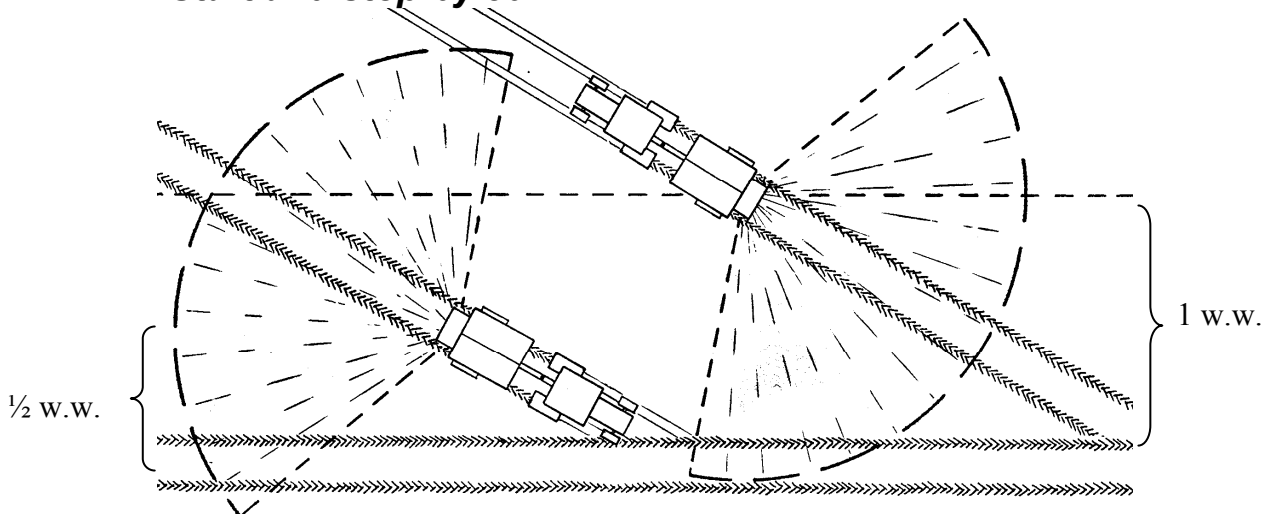

Towards headland tramline:

Disengage the metering system at a distance of $\frac{1}{2}$ the working width from the headland tramline. Slowly reduce the engine rpm before you disengage.

Away from tramline:

Engage the metering system at the working width from the headland tramline.

14.3 Start and stop by 60°

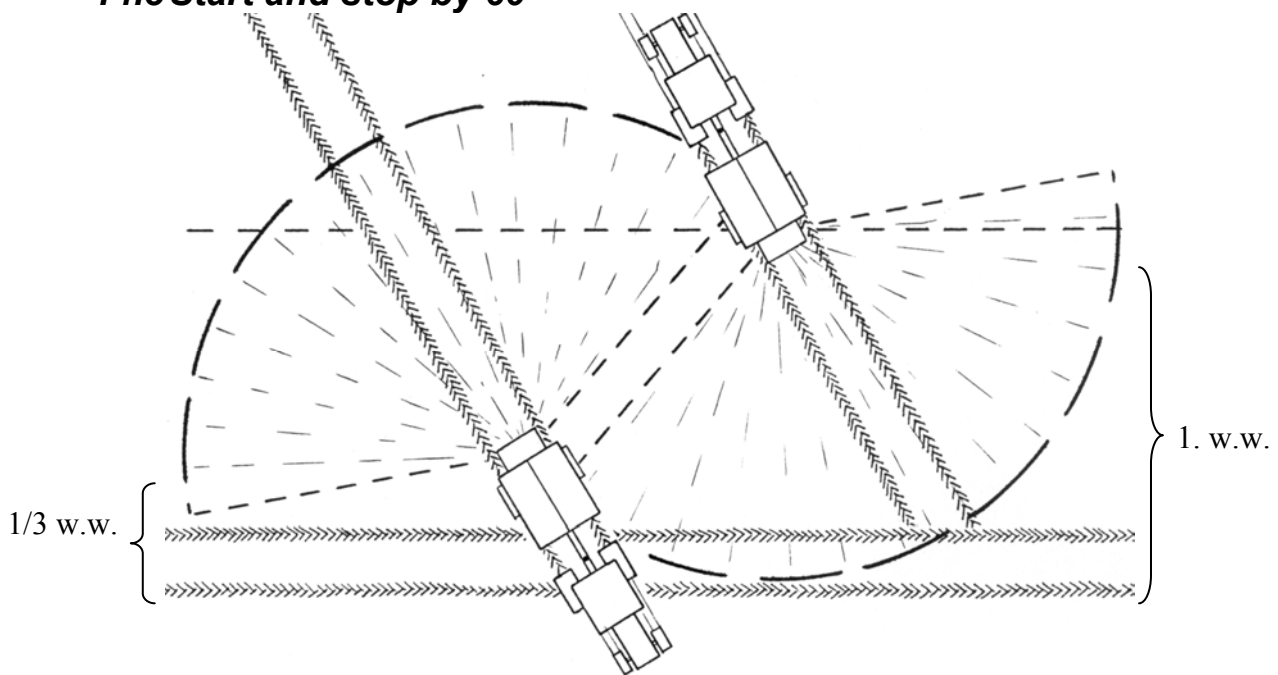

Towards headland tramline:

Disengage the metering system at a distance of 1/3 the working width from the headland tramline. Slowly reduce the engine rpm before you disengage.

Away from tramline:

Engage the metering system at the working width from the headland tramline.

15 Performing a static calibration test

1. Adjust the machine to the required application rate from the chart.
2. Dismount the spreading discs.
3. Put a minimum of 200kg in the hopper and turn the landwheel until there is an equal amount of material all the way from the feed gates to the end of the floorbelt.
4. Place a tray or a bucket under each downshute. (It is necessary to place a piece of cardboard or similar under each downshute to form a chute in order to guide the fertilizer into the bucket).
5. Turn the landwheel 11.5 times, turning the wheel at normal operating speed (about 1 revolution per second).
6. Weigh the fertiliser collected from both feed belts.
7. Multiply the weight collected with the factor from the chart below for the selected working width. The result is the number of kg/ha, which is applied.

Working width

Factor
meter

6	80
8	60
9	53,3
10	48
12	40
15	32
16	30
18	26,7
20	24
21	22,9
24	20
28	17,1
30	16
32	15
36	13,3

When this test is done, the cage wheel must turn with approx. the same speed as in a real situation. That means minimum 60 revs/min, equals 10 km/h wich gives 92 revs/minute on the cage wheel.

16 Special fertilisers

When spreading special fertilizer types, a spreading test with trays is always recommended. The details below should only be considered as guidance from Bredal.



16.1 N34 Prilled Ammonium Nitrate

Nedenfor er anført indstillinger til spredning af N34. Der bør ikke køres med mere end 800 pto omdr., heller ikke ved spredning på 24 m. arbejdsbredde eller mere.

Der bør altid foretages en spredeprøve i marken ved spredning af N34.

Kun god kvalitet kan spredes på 24-28 og 30 m. arbejdsbredde.

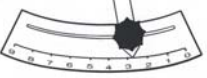
Settings for N34

A		
12 - 20 meter	Standard settings	800 rpm
24 meter	5	800 rpm
28 meter	6	800 rpm
30 meter	7	800 rpm

16.2 Pure potash

This fertilizer, such as Muriate of Potash, is very coarse and angular, so runs very slowly on the spreading vanes. It may help improve the spread pattern result by increasing the downshute set-

ting by 2 or 2.5 marks higher than the normal recommended setting for the spread width. The settings of the downshute should be increased from the standard settings

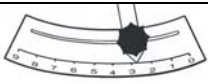
A	
12 - 16 m	2 scale settings higher
18 - 24 m	3 scale settings higher

Max 24 m. of working width by potash

Opposite to the normal rule of thumb, with this material it is important to choose the slowest floorbelt speed and the widest regulating slide opening from the chart. These materials run so slowly in the hopper that problems may be caused in keeping the regulating slides filled. It may be necessary to increase the regulating slide opening by approx. 10% compared with to the standard application rate setting guidelines.

16.3 Sulphate of Ammonia

By spreading of sulphate Ammonia the downshute settings must be higher than the standard settings.

12-16 m. working width 2 scales higher højere

18-24 m. working width 3 scales higher

24 m. working width is maximum for Sulphate of Ammonia

16.4 Prilled Urea

9-12 m. working width:

The tractor PTO speed may be increased up to 650-700 revolutions per minute if the particle strength is 1-1,5 kg minimum.

15-18 m working width:

It is possible to achieve acceptable spreading on overall working width, but not with double overlap. The settings of the downshutes should be at scale 5, and the tractor Pto speed determined by a spread tray test , to match the type of Urea and the working width.

20-24 m. working width:

Folow the procedure for 15 – 18m – however the particle size should be minimum of mean 2 mm.

The tractor Pto speed must be accurately maintained, as it correspond exactly to the working width.

Always carry out a spreading tray test before spreading Urea.

16.5 Granulated Urea

Granulated Urea has a rougher surface than prilled urea and normally is supplied with a mean particle size of 3 –3.5 mm and particle strength of 2-3 kg.

The standard settings of the spreader should be used for up to 24 metre working width. However the tractor Pto speed should not exceed 800 rpm if the particle size is 2 mm or less.

To compensate for reducing the tractor Pto speed at the wider working widths, the spreader should be raised as high as possible (spreading disc height 110 cm).

Always carry out a spreading tray test before spreading Urea.

17 Spreading of Slug Pellets, Rape and Mustard

When spreading slug pellets, rape or mustard seeds the Reduction Kit must be fitted under the regulating slides. When in position as shown below, the regulating slides are lowered to firmly hold the Reduction Kit in position, but not pressing too tightly on the floorbelts.

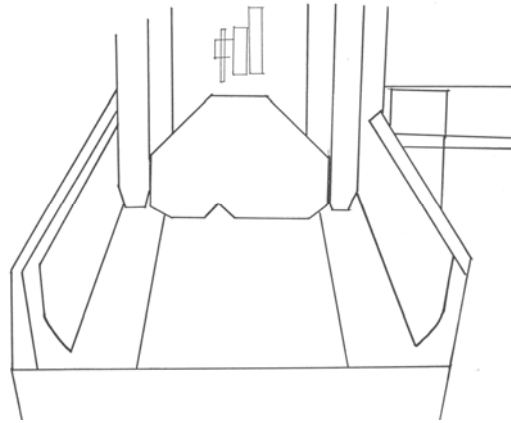

Slug pellet kit.

Spreading of Slug Pellets:

An application rate of approx. 4 kg/ha is applied at 1000 tractor Pto speed, using Axle 1 at 24 m working width.

Spreading of Rape and Mustard seeds.

The application rates available using the Reduction Kit are as follows:

- 5 kg/ha in Axle 1.
- 10 kg/ha in Axle 2.
- 20 kg/ha in Axle 3.

A static calibration test can be made in order to check the actual metered amount, see section 14

Max working width is 16-18 m., optimum is 10 – 12 m. at 800 rev/min on the pto.

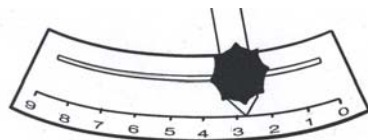

The following only applies to the spreading of rape and mustard:

- Move the downshutes to scale mark 0
- Rape runs very freely on the vanes, as it is very smooth, and therefore the downshutes must be set as described. Even at this setting the machine may apply a slightly higher rate in between the tracks than behind the machine..

18 Spreading of slug pellets (only for F2 and F2W with hydraulic rating)

Bredal recommend not to go further than 24 m and also not to spread these special seeds under windy conditions.

When spreading rape, mustard a.o. the best results are obtained on 12-18 m under calm wind conditions.

Settings by spreading:

The rear doors must be closed as much as possible which will correspond to a scale of 50. Materialet der ønskes spredt, afvejes med litervægten, og værdien aflæses.

The downshutes are set to 0.

Programming

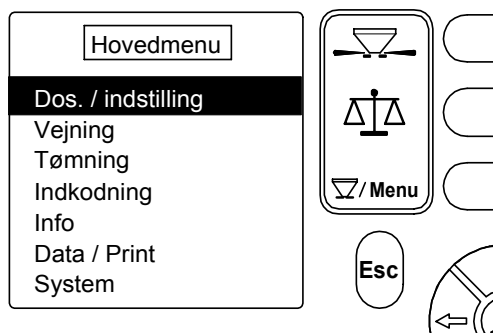

In the menu App. Rate setting the following must be put in:

- Setting of the scale on 50
- Spez. Weight of the material to be spread..
- Working width
- Kg / ha
- Downshute position (only on certain versions)

PTO speed:

- spreading of Rape, mustard a.s.o..
- spreading slug pellets

800 RPM

Same settings as by fertiliser.

Even though recommendations for a correct application and spreading are followed, Bredal still would like to emphasize that a spread test is done in order to ensure the best possible result.

19 Late application

Late application can be done in 2 ways:

1. The best distribution of the fertiliser is obtained by raising the spreader as high as possible (110 – 120 cm above the ground). The drop height of the fertiliser must only be 25 cm for obtaining a good distribution. That is why it's possible to spread in crops with a height of 70 to 80 cm with the late application equipment with a good result. Be aware of not to damage the blades of the crops. Use standard settings when using the late application equipment.
2. With late application equipment, it's possible to spread in crops in the same height as the height of the spread discs. The late application equipment is mounted on the arms holding the safety guards. It's important that the equipment is mounted total horizontally.
3. Always follow below recommendations with late application set mounted.

Settings for 12-36 m late application

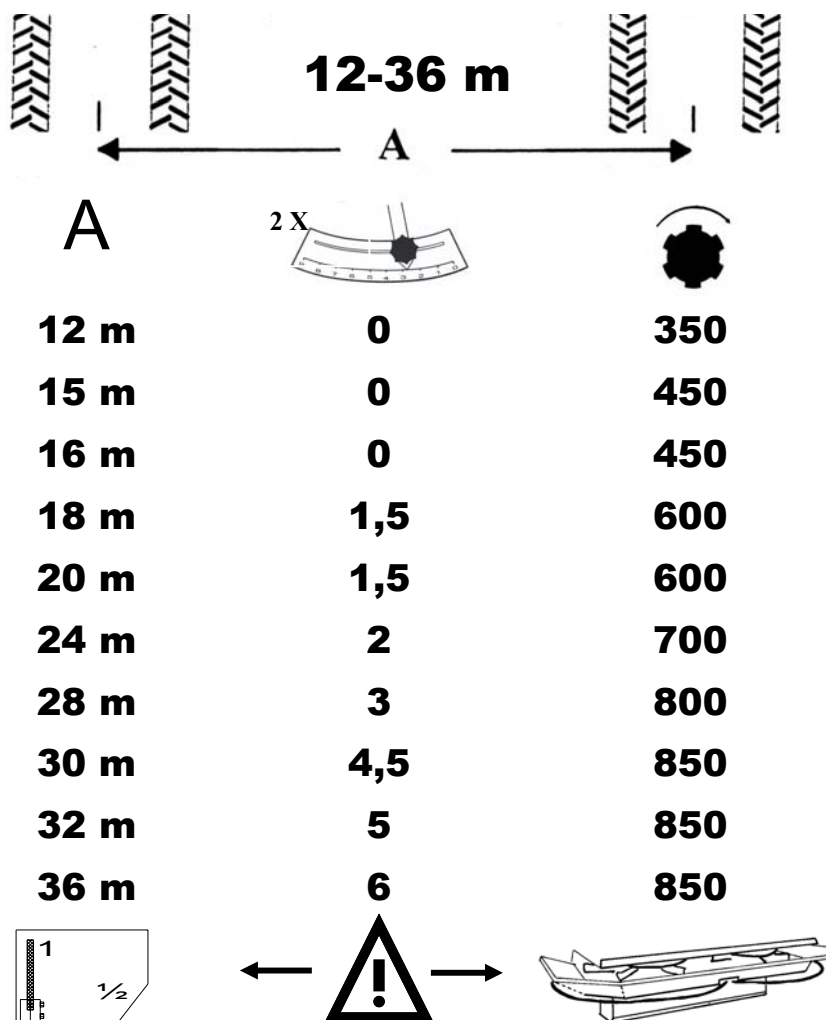

2 X = right and left downshute

⚠ Prilled fertiliser + 2 scale steps on the downshutes





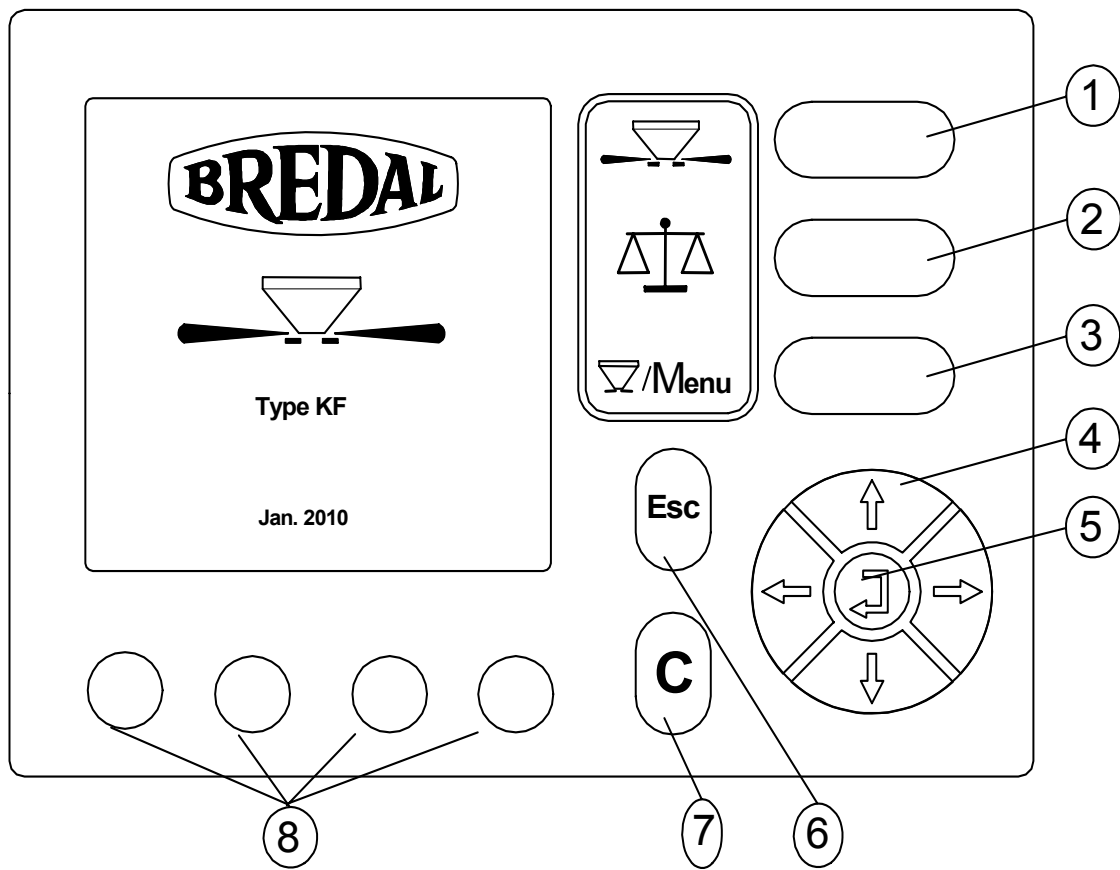





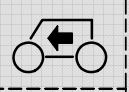



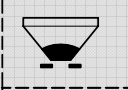

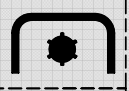
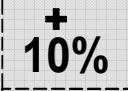
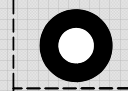
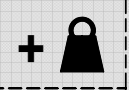
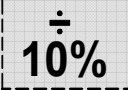
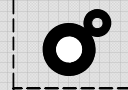

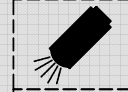

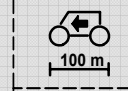
20 F2W with hydr rating and load cell

F2W with hydr. Rating and load cell

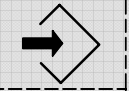
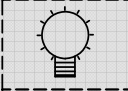

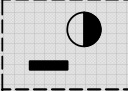
Pos.	Beskrivelse
1	Start-/Stop key
2	Load key
3	MENU key
4	Piletaster
5	Return (enter) key
6	Escape key
7	Clear key
8	Program keys

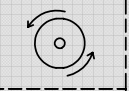
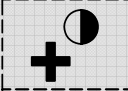
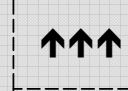
20.1 Symbol selection

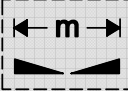
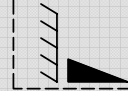
	Km/h		Time		Alarm OFF
	Area		Kg left		Alarm ON
	RPM PTO		+10%		Wheel tractor
	Kg		-10%		Wheel spreader
	Calibration		Right		Radar
	Filling		Left		Speed auto-calibr.
	Kg/min.		Light turns on by pressing any key.		Reg. down
	Save		Turn on light		Reg. up
	Kg/ha		contrast -		Next page
	RPM Oilmotor		contrast +		Last page
	Ton		Working width		Headland spreading

21 Start up

21.1 Speed sensor

On spreaders with hydrating by computer control, there has to be mounted a speed sensor on the tractor. The easiest and most simple is to mount a magnetic sensor on the cardanshaft for the 4 wheeldrive. Some tractors have a standard plug, where the forward speed can be taken.

21.2 Power supply for the computer

Most tractors have a 3 pin ISO plug, if this plug is not in the tractor a Bredal powerbox can be purchased.



NOTE, if the 3 pin power plug has been cut of, or demounted, there is no guarantee on the computer.

21.3 Monting the computer

Mount the computer so it is to operate from the driver seat. Put the 3 pin ISO plug, in the tractor power plug. Connect the plug from the spreader to the plug from the computer (Note leave the connection inside the cabin). The short wire with the silver plug, should not be used.

21.4 Encoding forward speed

Measure out a distance of 100m, and bring the tractor to the start mark.

Press the **menu** key and choose **encode**, press enter and choose **Speed Sensor**, press enter choose either radar or wheel sensor, with the softkey buttons under the screen. Press the button **drive 100m**, and drive the 100m, and then press enter to save the counted impulses.

There should as minimum be 3-400 impulses pr 100 meter.

It is also possible to press in the no. of impulses if this no. is known.

21.5 Calibration of hydraulic system

The P.valve has been calibrated from the factory. However under some circumstances it can be necessary to do this again.

The tractor engine should go with normal rotations as when working, while the p.valve is calibrated. Press **menu**, move the cursor to mark **encode**, and press enter, choose **hydr. Calibration**, and press enter, wait to the calibration is done, this will take 3-4 minutes.

Start-/stop key (pos. 1)

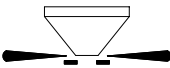
Key	Description
	By pressing this key, you will start or stop spreading when spreading this symbol is shown on screen.

Calibration key (pos. 2)

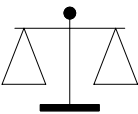
Key	Description
	By pressing this key, the kg spread per ha, is calculated out of total spread amount, and covered area. This function can only be used when spreading is stopped and tractor is parked.

Menu key (pos. 3)

Key	Description
 /Menu	By pressing menu, you go from main screen, to working menu.

Arrow keys (pos. 4)

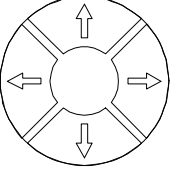
Key	Description
	The arrow keys are used to navigate around in the menus. When encoding values the arrow keys up and down are used to choose no. from 0-9.

Return key (enter) (pos. 5)

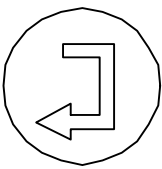
Key	Description
	The return key is used to approve values or menu points.

Esc tast (pos. 6)

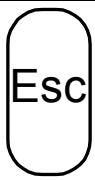
Key	Description
	The escape key is used, when you want to go back in menu, without saving your changes.

Clear key (pos. 7)

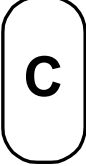
Key	Description
	The clear key is used to reset values, and to confirm alarms.

Program keys (softkeys) (pos. 8)

Key	Description
 taste 1 - 4	The function of the program keys are shown in the operation screen. Each function is shown on the screen, directly above the actual key.

22 Operation

The operation screen is displayed when you press the MENU key, no matter where you are in the program. The operation screen is the first thing displayed when the device is switched on.

Correct operation requires that all data entry/calibration has been carried out.

22.1 Operation screen

The operation screen is divided into the following sections. These sections are described below.

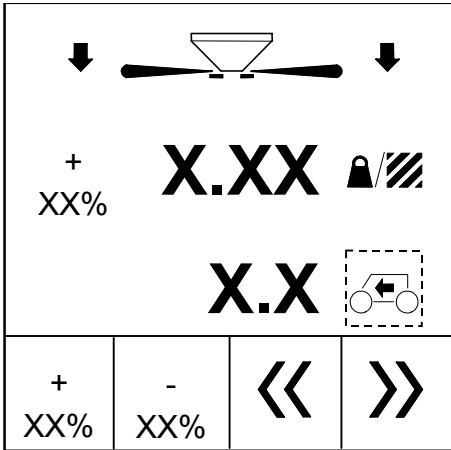
State of the spreader		<i>The arrows shows whether the app. Rate is being increased (up arrow) or decreased (down arrow)</i>
Step app rate status		App. Rate shown in kg/ha
		Operation function 2 (selectable)
Step app rate: + = increase. - = decrease		Change operation function 2.

State of spreader

Shows whether the spreader is in function or not.

Step app. rate

The application rate can be change in increments equivalent to the number of per cent chosen under settings. If the +/- step application rate keys are activated, these are shown on the display, along with the percentage amount the application rate has been changed by. The size of the increments is the same for both + and – stepping.

22.2 Operation function 2

This operating function is selectable, i.e. the function displayed on the screen can be selected using the PROGRAM keys. Press PROGRAM key 3 or 4 to select from all the available operating functions. Each operating function is described below:

Speed

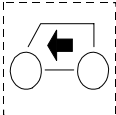
Key	Description
	The actual speed showed in km/h

Kg left

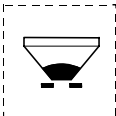
Key	Description
	Remaining amount of kg left in the hopper. Weighed by the weighing system.

Areal

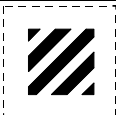
Key	Description
	Area worked since last reset, shown in ha. Area counting is with 2 decimals up to 99.99 ha, hereafter with one decimal up to 999.9 ha, larger is shown without decimals.

Kg-counter

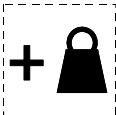
Key	Description
	Quantity of fertilizer spread since last reset. Shown in kg up to 9999 kg, hereafter in tonnes, when going to tonnes, a "T" is shown in the symbol.

Time

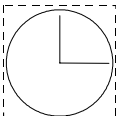
Key	Description
	The timeuse for spreading.

Pto speed

Key	Description
	Shows the rotations on the pto, shown in rpm. When spreading into headland, the rotations on disc into headland is shown.

Floorbelt speed

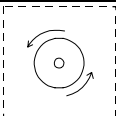
Key	Description
	The speed on the oilmotor, shown in revolutions per minute

Kg/minute

Key	Description
	The quantity being spread shown in kg/min.

22.3 Hydraulic change of headland gear (Optional equipment)

When the spreader is equipped with hydraulic controlled change of headland gear, the headland gear will be activated through a double hydraulic outlet on the tractor. When the headland spreading is active, a symbol is visible in the upper left corner of the screen (only for spreaders with hydraulic change of headland gear). The pto axle has to have stopped before you can change to and from headland gear.

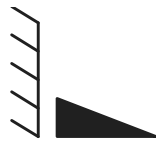

When this symbol is shown, you have an activated headland gear.



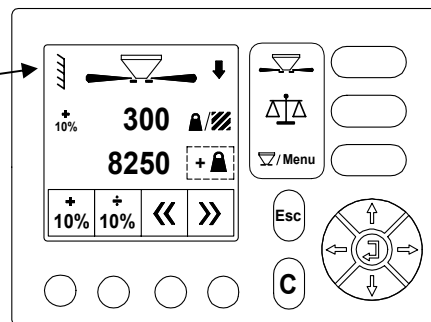



No symbol is shown, if the spreader is bought without hydraulic activation of headland gear..



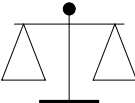

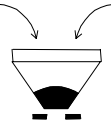
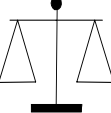
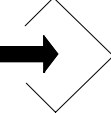

22.4 Calibration of the application rate

By pressing the calibration key, it is possible to make an average calibration of the total spread dosage since last calibration. The average dosage is calculated out of the amount spread, and the weighed amount.

The average application is calculated like this (with load cells):

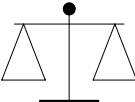
Step/key	Description										
 1	Press CALIBRATION key, and this screen will occur: <table border="1" style="margin: 10px auto; width: 80%;"> <tr> <td colspan="2" style="text-align: center;">App. Rate Kg/ha</td> </tr> <tr> <td>Calculated</td> <td style="text-align: right;">XXXX</td> </tr> <tr> <td>Weighed</td> <td style="text-align: right;">XXX</td> </tr> <tr> <td>Actual flow factor</td> <td style="text-align: right;">X.XX</td> </tr> <tr> <td>New flow factor</td> <td></td> </tr> </table>   	App. Rate Kg/ha		Calculated	XXXX	Weighed	XXX	Actual flow factor	X.XX	New flow factor	
App. Rate Kg/ha											
Calculated	XXXX										
Weighed	XXX										
Actual flow factor	X.XX										
New flow factor											
 2	Press the <i>filling</i> key (softkey) to start a new calibration.										
3.	Spread a suitable amount (depending on wished application)										
 3	By pressing <i>weighing</i> (softkey) the average dosage is being re calculated, and the computer will suggest a new flowfactor.										
 4	If the new flow factor is acceptable Press the <i>save</i> (softkey), and the new flowfactor is saved. The spreader is weighing automaticly and spreading can continue.										
5.  /Menu	If the new flowfactor is not acceptable: Press the MENU-key and continue spreading, until a larger amount has been spread.										

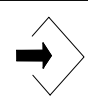
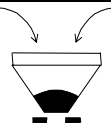
22.5 Calibration without load cells

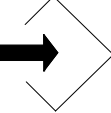
Step/key	Description								
<p>1</p> 	<p>Press the CALIBRATION key, and this screen will occur:</p> <div style="border: 1px solid black; padding: 5px; margin: 10px auto; width: fit-content;"> <p style="text-align: center;">App. Rate Kg/ha</p> <table style="width: 100%; border-collapse: collapse;"> <tr> <td style="padding: 2px;">Calculated</td> <td style="padding: 2px; text-align: right;">XXXX</td> </tr> <tr> <td style="padding: 2px;">Weighed</td> <td style="padding: 2px; text-align: right;">XXX</td> </tr> <tr> <td style="padding: 2px;">Actual flow factor</td> <td style="padding: 2px; text-align: right;">X.XX</td> </tr> <tr> <td style="padding: 2px;">New flow factor</td> <td></td> </tr> </table> </div> <div style="display: flex; justify-content: space-around; margin-top: 10px;">    </div>	Calculated	XXXX	Weighed	XXX	Actual flow factor	X.XX	New flow factor	
Calculated	XXXX								
Weighed	XXX								
Actual flow factor	X.XX								
New flow factor									
<p>2</p> 	<p>Press the filling button, and enter the amount loaded. This are done when loading the spreader</p>								
<p>3</p> 	<p>When the application rate are calculated, press the <i>weighing</i> (soft-key) and the actual amount left in the hopper is entered.</p>								
<p>4</p> 	<p>A new flow factor is automaticly being calculated by pressing save (softkey).</p>								

22.6 Main menu

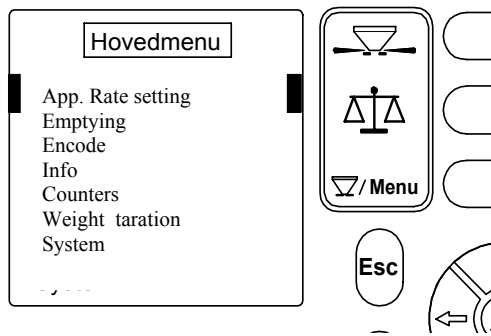

In the main menu you can choose following

1. App rate / settings
2. Emptying
3. Encode
4. Info
5. Counters
6. Weight taration
7. System

22.6.1 App. Rate /settings

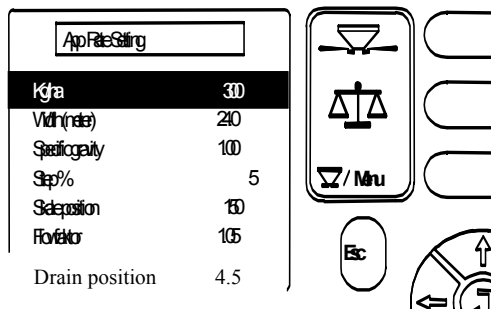

Here you give the computer the basic information about the task, that is necessary.

The app. Rate /settings menu is selectable from the main menu, and here the wished application rate is entered.

1. Kg/ha

The wanted application rate is entered in **KG/HA**

2. Working width

The chosen working width is entered in Meters

3. Specific gravity

The weight of the fertilizer is entered in **KG/L**

4. Step %

Enter the procentage you want your step to be.

5. Scale position

The actual rear door setting is encoded (80-300) by normal fertilizer spreading a rear door opening of 150-200 would be right.

6. Flowfactor



The flow factor, if this is known can be encoded. Otherwise start out with 1,00

7. Drain position

The computer will automaticly choose the standard drain position for the down chutes, for the chosen working width, if other settings are required, it can be entered here.

22.6.2 Emptying

The spreader can be emptied without driving, as follows:



Step/Key	Description
1  /Menu	Press the MENU-key.
2	Move the cursor, by the up or down arrows, and choose emptying
3	Press the enter (return) key
4 	You can now empty the spreader, by pressing the start/stop key.

22.6.3 Encode

The encode menu is selectable in the main menu, by using the arrow keys, to move the cursor, and the enter key to select.

22.6.3.1 Alarms

Encoding of alarms, is chosen in the encode menu, by highlighting *Alarms*, and press enter. Those alarms available are turned on and off with the softkeys. To confirm reading off an alarm, press C (clear)

Key	Description
	Alarm activated
	Alarm off.

Kg left alarm



Alarm ON/OFF and the no of kgs you want to have an alarm at.

Rpm disc alarm

Alarm ON/OFF and the minimum rotations on the disc you want the alarm given.

22.6.3.2 Speed sensor

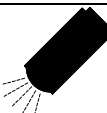
Selectation of speedsensor and calibration figure for speedsensor is encode here. It is also possible to calibrate the speed sensor. This is selected in this menu, by chosing *Speed sensor*.

Key	Description
	By pressing (softkey 1) you will select radar as speed sensor (7 pin DIN/ISO plug) <i>If the no. of impulses pr 100m is known, this no. can be encoded..</i>
	By pressing (softkey 2) you choose Wheelsensor mounted on tractor, as speedsensor. By the 7 pin DIN/ISO plug. <i>If the no. of impulses pr 100m is known, this no. can be encoded...</i>
	By pressing (softkey 3) you select wheelsensor on spreader, as speedsensor through the 21pin plug. <i>If the no. of impulses pr 100m is known, this no. can be encoded.</i>

Automatic speed calibration

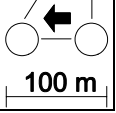
Step/key	Description
1	Measure out a 100m distance, and go to startmark.
2	Select speed sensor as described above.
3 	Press this key, and drive the 100m, the computer will count the impulses as you go.
4	Press enter to accept the calibration of the speed sensor.

22.6.3.3 Hydraulic calibration

It is not normally necessary to calibrate the proportional valve. Calibration has been done at the factory. However, if there are problems with the hydraulic system it may be necessary to calibrate again.

Select this menu from the settings menu by selecting “**Hydr. calibration**” using the UP and DOWN arrows. Then press the ENTER key. The procedure for calibrating the proportional valve is as follows:

1. The hydraulic oil must be at normal operating temperature and the spreader must be empty.
2. The tractor motor must be running at normal operating speed. Press the ENTER key.
3. The cell wheel will run up to maximum speed, and the speed will then be reduced until the cell wheel stops.
4. Once calibration is finished, the display returns to the calibration menu. If the hydraulic motor is unable to reach a minimum speed of 500 RPM, an alarm is raised.

22.6.3.4 Application rate calibration

Application rate calibration has normally been carried out at the factory and does not need to be done by the user. It will only be necessary to do it in special circumstances.

Select this menu from the settings menu by selecting “**App. Rate calibration**” using the UP and DOWN arrows. Then press the ENTER key.

For operational accuracy, the number of cm³ which is released per pulse needs to be set. If the quantity released per pulse is known in advance, it can be set directly.

Otherwise the quantity released per pulse can be automatically calculated by calibrating the system as follows:

1. Select “**New calibration**” and press the RETURN key.
2. Enter the specific gravity (density) of the fertilizer (**very important**).
3. Press the ENTER key and the cell wheel is made ready (the cell wheel rotates and is filled with fertilizer).
4. Empty the spill tray.
5. Press the START/STOP key to start the calibration (the cell wheel will turn).
6. Once a sufficient quantity has been released, stop the cell wheel by pressing the START/STOP key.
7. Weigh the quantity released and enter the weight.
8. Press the ENTER key and the app. rate calibration is complete.

22.6.3.5 Weighing

The weighing system is normally calibrated from the factory, so normally it is not necessary to make a calibration of this. If the weighing is not right, it is possible to make a new calibration.

Step/Key	Description
1  /Menu	With an empty spreader , press Menu.
2	Move the cursor by the up and down keys, to Weighing .
3	Press enter
4	Move the cursor by the up and down keys, to Calibration .
5.	Press enter, and following warning will be shown.

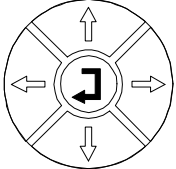
	<div style="border: 1px solid black; padding: 5px; text-align: center;"> <div style="border: 1px solid black; padding: 2px; margin-bottom: 5px;">Calibration</div> <div style="background-color: black; color: white; padding: 2px; margin-bottom: 5px;">Warning</div> <p>Continue cal. ? Are you sure ? ESC = exit</p> </div>
<p>6.</p>	<p>When you want to calibrate the weighing system, press enter.</p> <p>With empty spreader and no rpm on the pto, press enter and the system will be reset.</p>
<p>7.</p>	<p>Put a known weight in the hopper and encode this weight in kg. And press enter</p> <p>A new calibration figure is being calculated, and the calibration is through.</p>

Calibration figure

If the calibration figure is known, this can be entered directly, by selecting **Calibration Figure**, and entering the known figure, with the arrow keys, and press enter.

22.6.4 Info

The information menu displays an overview of the various settings, and can be accessed from the main menu (press the MENU key). Then use the UP and DOWN arrows to select “**Info**”, and press the ENTER key.

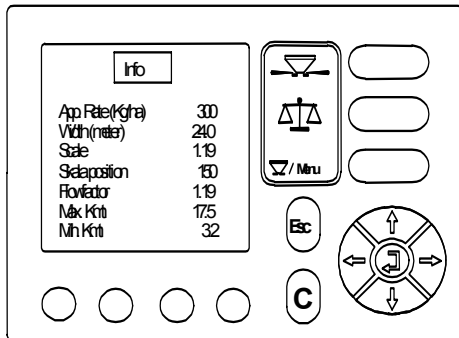

In the info menu, it is possible to get a quick view of the most basic information.

1. App. rate
2. Working width
3. Specific gravity
4. Scale position
5. Flow factor
6. Max. Km/h
7. Min. Km/h

22.6.5 Counters

It is possible to have up to ten different trip counters (jobs) in operation, which can be started and stopped, for example, when changing to another field.

The trip counter menu can be accessed from the main menu (press the MENU key). Then use the UP and DOWN arrows to select “**Trip counter**”, and press the ENTER key.

When you start a new job, the counters are reset. If you change to another job, and then change back again to the first job, the counters will continue counting from their previous values.

Jobs can be reset individually.

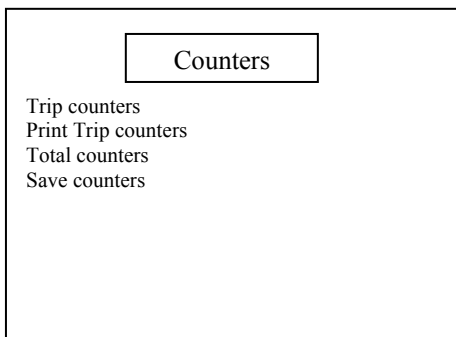

This screen is shown when the menu point **counters** is selected.

Tællerne i en opgave

Trip counter	
1/10	
New counter	
Delete counter	
Kg	X
Area	X.XX
Time	X:XX

This window is displayed when you select the “**Trip counter**” menu. The individual counters are described below:

Beside the mentioned functions it is also possible to name the different counters, (letters are selected with arrow keys)

Kg:

The total number of kg spread since the job was started or last reset.

Area:

The accumulated area worked since the job was started or last reset. This area corresponds to the effective area, i.e., only the area which has been spread.

Time:

The total effective time spent since the job was started or last reset.

Start/continuing a task

When you select the “**Trip counter**” menu, the last job you accessed is re-opened. If this is the very first job you are starting, job one will be opened.

Trip counter		
Counter no	1	
Counter no	2	
Counter no	3	
Counter no	4	
Counter no	5	
Counter no	6	
↓	↓	↓

To start or continue another job, press the “**New counter**” key. You can then select between jobs 1 – 10 by using the UP and DOWN arrow keys to highlight the desired number. Then press the ENTER key.

To return to the operation screen, press the MENU key.

Resetting a task

If you want to reset the counters for a job, select the job as described above, and then select “**Delete counter**” and press the ENTER key.

When menupoint **Counter X** is selected Når menupunktet Tæller X vælges, vises automatisk det sidst anvendte sæt triptællere. Der er nu følgende muligheder: **Der kan tælles videre i det valgte sæt triptæller (de aktive).**

The counters will stay active until you select a new. Through the menupoint **New Counter** you can choose up to 10 different trip counters.

Deleting data in counters

With the arrow keys choose **delete counter**, and press enter. The chosen counter will be deleted.

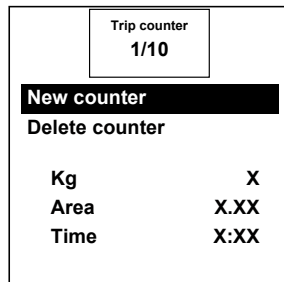

Kg (A.) = Exact weight counted by the load system. A correct counting will only occur when using the **Calibration of application**, for all fertilizer spread in the field.

Kg (B.) = Calculated weight by the impulses from the application unit.

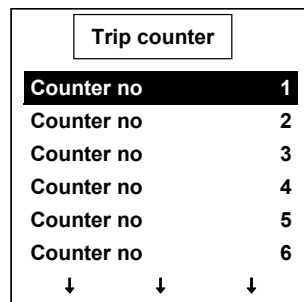

New counter:

The cursor placed on the counter you want active, and press enter. Now data will be saved in the selected counter.

The different counters are numbered, but it is also possible to name the different counters.

22.6.5.1 Print counters

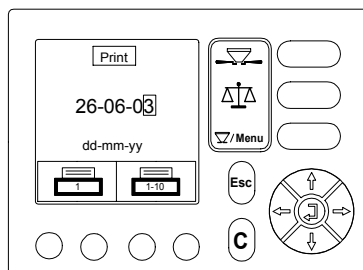

In the shown screen it is possible to print the data. There is 2 options

1. Encode the date you want on the print
2. Print the active counter
3. Print all trip counters.

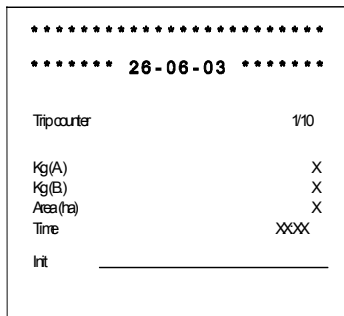

Example

22.6.5.2 Total counters

In this menu, you can see total counters, counting total amount of kg's spread, total area spread, total time spend spreading.

22.6.5.3 Save counters

Here there is 2 options, you can either choose to save the counters in a HTML file, (shown by internet). Or in a CVS file, this file can be opened in an excel sheet. Move the cursor to the wished format, and press enter.

22.6.6 Weight Taretion

The weighing menu is selected in the main menu, by pressing the Menu key, and using the up and down arrows to mark and the enter key to select.

22.6.6.1 Tare

The spreader has to be empty and the pto has to be stopped to make a taretion.

To make a taretion (reseting) the weighing system, select **Tare** and press enter 2 times, now the weighing system is tared.

22.6.6.2 Tare Frequency

XXXXX

With the load system it is possible to:

Show the actual kgs in the hopper, to calculate the average dosage, out of the fertilizer spread and the ha driven.

22.6.7 System

The system menu can be accessed from the main menu (press the MENU key). Then use the UP and DOWN arrows to select "**System**", and press the ENTER key.

22.6.7.1 Contrast/light

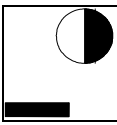
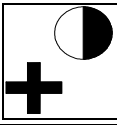
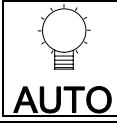
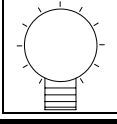
Key	Description
	Press this program key to make the display brighter.
	Press this program key to make the display darker.
	Press this program key to activate the auto light feature. The display light turns off, and turns on automatically when any key is pressed.
	Use this key to turn the display light on and off.

22.6.7.2 Language

This option allows you to choose the working language for the LH Bredal 500 computer. Select your language and press softkey no 3, to confirm.

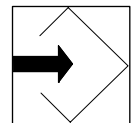

22.6.7.3 Speed simulation

It is possible to simulate a speed, for example when troubleshooting or when you wish to spread independent of the driving speed. You can enter the desired simulated speed in km/h, with 1 decimal place. The speed simulation can be started and stopped using Softkeys 1 & 2.

22.6.7.4 Test

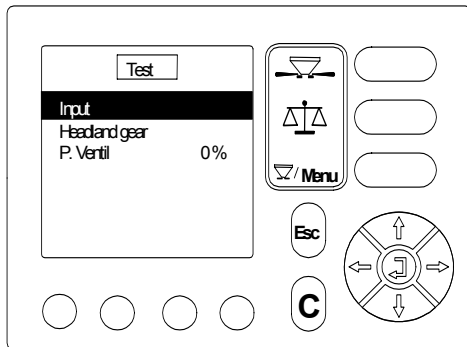

Valg af test input, kant/nedløbsposition eller P. Ventil

Test input

Use the test input feature if, for example, you believe a sensor may be defective.

For each input, there is a counter shown on the right side of the display which indicates the number of times that input has been activated (the counter resets automatically when you leave the “**Test Input**” menu, or if you press the C key). On the left side, the instantaneous status of the input is shown (**Hi/Lo**).

You can page through the inputs by pressing the UP and DOWN arrows (2 pages in total).

The input names displayed correspond to the following items:

Input	Description
Wheel DIN/ISO	Speed signal from the wheel sensor installed on the tractor (via the 7-pin DIN/ISO connector in the tractor).
Radar DIN/ISO	Speed signal from the radar installed on the tractor (via the 7-pin DIN/ISO connector in the tractor).
RPM cell wheel	Signal from the RPM sensor mounted near the cell wheel.
Press the DOWN arrow key to see the next set of inputs:	
RPM disc	Signal from the RPM sensor mounted near the discs.
Weighing	Signal from the weighing system.
Press the UP arrow key to see the first set of inputs:	

Test headland gear

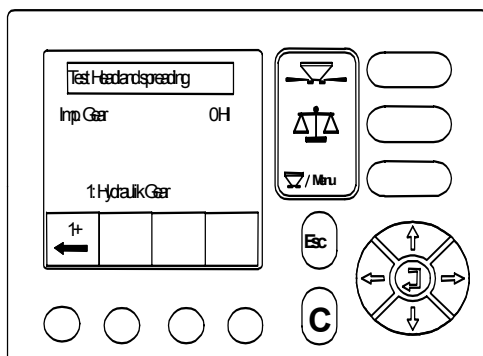

In the shown screen, the hydr valve for the headland gear can be tested.

In top it is shown if the sensor for the gear is giving impulses when activated.

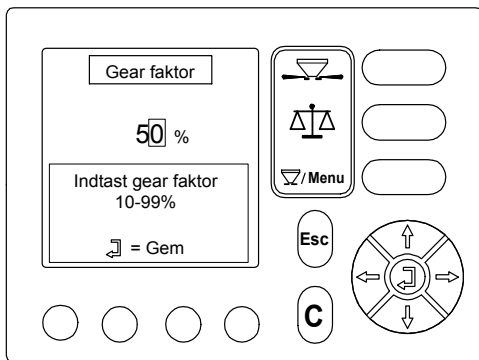

In the shown screen, there decreasing percentage, for the headland gear is shown

12-28 m Headland spreading = 55 %

28-36 m Headland spreading = 33 %

Test p. ventil

In order to test the hydraulic motor's proportional valve, you must specify a "duty cycle %". Enter the desired duty cycle percentage, and then press the ENTER key.

23 Operation alarms

Situations can arise during operation that cause an alarm to be raised. The various alarms can be acknowledged by pressing the C key.

Carefully investigate why an alarm occurred before acknowledging the alarm.

Below is an explanation of the "standard" alarms which can occur:

Application rate is outside the possible range:

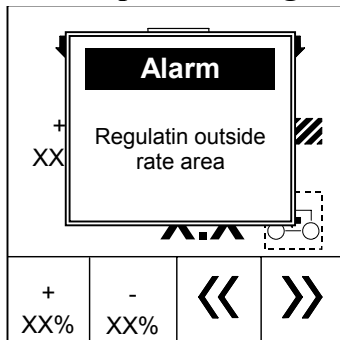

The desired app. rate cannot be reached with the current settings and driving speed. Slow down, and the alarm will automatically disappear.

Max. Flow exceeded:

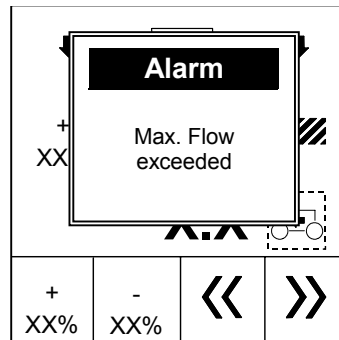

The maximum flow rate for the spreader has been exceeded, slow down or change the app. rate setting.

Min. RPM for the cell wheel not reached:

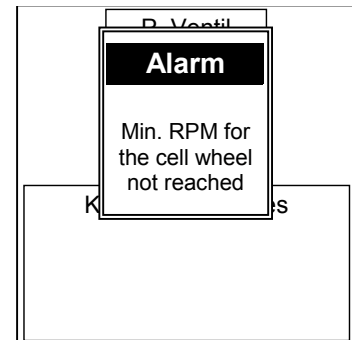

The minimum rotating speed for the cell wheel (500 RPM) cannot be reached. This alarm is only displayed during calibration of the hydraulic motor.

24 System plans

